

DIGITAL SERVO DRIVE FOR BRUSH & BRUSHLESS MOTORS

CONTROL MODES

- Indexer, Point-to-Point, PVT
- Camming, Gearing
- Position, Velocity, Torque

COMMAND INTERFACE

- CANopen
- ASCII and discrete I/O
- Stepper commands
- ±10V position/velocity/torque (2 inputs)
- PWM velocity/torque command
- Master encoder (Gearing/Camming)

COMMUNICATIONS

- CANopen
- RS-232

FEEDBACK

Incremental

- Digital quad A/B encoder
- Analog sin/cos encoder
- Panasonic Incremental A
- Aux. encoder / encoder out

Absolute

- SSI
- EnDat 2.1 & 2.2
- Absolute A
- Tamagawa Absolute A
- Panasonic Absolute A Format
- BiSS (B&C)

Other

- Digital Halls

I/O DIGITAL

- 12 High-speed inputs
- 2 Motor over-temp inputs
- 8 Opto-isolated inputs
- 5 Opto-isolated outputs
- 2 Opto-isolated motor brake outputs

I/O ANALOG

- 2 Reference inputs, 14-bit

SAFE TORQUE OFF (STO)

- SIL 3, Category 3, PL d

DIMENSIONS: IN [MM]

- 9.24 [234.7] x 5.42 [137.6] x 3.59 [91.1]

DESCRIPTION

XP2 sets new levels of performance, connectivity, and flexibility. CANopen communication provides a widely used cost-effective industrial bus. A wide range of absolute encoders are supported.



Model	Vac	Ic	Ip
XP2-230-20	100~240	10	20
Add -R to model number for resolver option			

High resolution A/D converters ensure optimal current loop performance. Both isolated and high-speed non-isolated I/O are provided. For safety critical applications, redundant power stage enable inputs can be employed.

GENERAL SPECIFICATIONS

Test conditions: Wye connected load: 2 mH line-line. Ambient temperature = 25° C. Power input = 230 Vac, 60 Hz, 1 Ø

MODEL	XP2-230-20	
OUTPUT CURRENT (EACH AXIS)		
Peak Current	20 (14)	Adc (Arms, sinusoidal)
Peak time	1	s
Continuous current (Note 1)	10 (7)	Adc (Arms, sinusoidal)
INPUT POWER		
Mains voltage, phase, frequency	100~240	Vac, ±10%, 1 Ø or 3 Ø, 47~63 Hz
Mains current	20	Arms
+24 Vdc Control power	+20 to +32 Vdc, 500 mA max	Required for operation
DIGITAL CONTROL		
Digital Control Loops	Current, velocity, position. 100% digital loop control	
Sampling rate (time)	Current loop: 16 kHz (62.5 µs), Velocity & position loops: 4 kHz (250 µs)	
Bus voltage compensation	Changes in bus or mains voltage do not affect bandwidth	
Minimum load inductance	200 µH line-line	
COMMAND INPUTS (NOTE: DIGITAL INPUT FUNCTIONS ARE PROGRAMMABLE)		
<i>Distributed Control Modes</i>		
CANopen	Position, Velocity, Torque (Profile & Interpolated modes), Homing	
<i>Stand-alone mode</i>		
Analog torque, velocity, position reference	±10 Vdc, 14 bit resolution	Dedicated differential analog input
Digital position reference	Pulse/Direction, CW/CCW	Stepper commands (2 MHz maximum rate)
	Quad A/B Encoder	2 M line/sec, 8 Mcount/sec (after quadrature)
Digital torque & velocity reference	PWM, Polarity	PWM = 0% - 100%, Polarity = 1/0
	PWM 50%	PWM = 50% ±50%, no polarity signal required
	PWM frequency range	1 kHz minimum, 100 kHz maximum
	PWM minimum pulse width	220 ns
Indexing	Up to 32 sequences can be launched from inputs or ASCII commands.	
Camming	Up to 10 CAM tables can be stored in flash memory	
ASCII	RS-232, 9600~115,200 Baud, 3-wire, RJ-12 connector	
DIGITAL INPUTS		
Number	22	
[IN1,11]	Digital, Schmitt trigger, 1 µs RC filter, 24 Vdc compatible, programmable pull-up/down to +5 Vdc/ground, Vt+ = 2.5~3.5 Vdc, VT- = 1.3~2.2 Vdc, VH = 0.7~1.5 Vdc	
[IN21, 22]	Same specs as IN1 & IN11, but with fixed pull-up to +5 Vdc	
[IN2~5,12~15]	Programmable as single-ended or differential pairs, 100 ns RC filter, 12 Vdc max, 10 kΩ programmable pull-up/down per input to +5 Vdc/ground, SE: Vin-LO ≤ 2.3 Vdc, Vin-HI ≥ 2.7 Vdc, VH = 45 mV typ, DIFF: Vin-LO ≤ 200 mVdc, Vin-HI ≥ 200 mVdc, VH = 45 mV typ, Opto-isolated, single-ended, ±15~30 Vdc compatible, bi-polar, 2 groups of 4 with common return for each group	
[IN6~9,16~19]	Rated impulse ≥ 800 V, Vin-LO ≤ 6.0 Vdc, Vin-HI ≥ 10.0 Vdc, Input current ±3.6 mA @ ±24 Vdc, typical	
[IN10,20]	Motor overtemp signals on feedback connectors, , Schmitt trigger, 24 Vdc compatible 330 µs RC filter, 4.99k pullup to +5 Vdc, Vt+ = 2.5~3.5 Vdc, VT- = 1.3~2.2 Vdc, VH = 0.7~1.5 Vdc	
ANALOG INPUTS		
Number	4	
[AIN1~2]	Differential, ±10 Vdc, 5 kΩ input impedance, 14-bit resolution	
[AIN3~4]	Single-ended, motor temperature sensor, 4.99 kΩ pulled-up to +5 Vdc, 12-bit resolution	
SAFE TORQUE OFF (STO)		
Function	PWM outputs are inactive and current to the motor will not be possible when the STO function is asserted	
Standard	Designed to IEC-61508-1, IEC-61508-2, IEC-61800-5-2, ISO-13849-1	
Safety Integrity Level	SIL 3, Category 3, Performance level d	
Inputs	2 two-terminal: STO-IN1+,STO-IN1-, STO-IN2+, STO-IN2-	
Type	Opto-isolators, 24V compatible, Vin-LO ≤ 6.0 Vdc or open, Vin-HI ≥ 15.0 Vdc,	
Input current (typical)	STO-IN1: 9.0 mA, STO-IN2: 4.5 mA	
Response time	2 ms from Vin ≤6.0 Vdc to interruption of energy supplied to motor	
Reference	Complete information and specifications are in the Xenus Plus 2-Axis STO Manual	
DIGITAL OUTPUTS		
Number	7	
[OUT1~5]	Opto-isolated Darlington, 20 mA max, 24 V tolerant, collector & emitter connections	
[OUT6~7]	Motor brake control: opto-isolated, current-sinking with flyback diode to +24 Vdc, 1 Adc max	
RS-232 PORT		
Signals	Rx/D, Tx/D, Gnd in 6-position, 4-contact RJ-12 style modular connector	
Mode	Full-duplex, DTE serial communication port for drive setup and control, 9,600 to 115,200 baud	
Protocol	Binary and ASCII formats	
CAN PORT		
Signals	CANH, CANL, Gnd in 8-position dual RJ-45 style modular connector, wired as per CAN Cia DR-303-1, V1.1	
Format	CAN V2.0b physical layer for high-speed connections compliant	
Data	CANopen Device Profile DSP-402	
Address selection	16 position rotary switch on front panel with 3 additional address bits available as digital inputs or programmable to flash memory (7-bit addressing, 127 nodes per CAN network)	
STATUS INDICATOR LEADS		
Drive Status	Bicolor LED, drive status indicated by color, and blinking or non-blinking condition	
CAN Status	Bicolor LED, status of CAN bus indicated by color and blink codes to CAN Indicator Specification 303-3	
5V OUTPUT		
Number	4, two on the feedback connectors (J10, J11), two on the control connector (J12) for the A and B multi-mode ports	
Ratings (each)	+5 Vdc @ 500 mA, thermal and overload protected	

GENERAL SPECIFICATIONS

REGENERATION

Operation	Internal solid-state switch drives external regen resistor (see Ordering Guide for types)	
Cut-In Voltage	+HV > 390 Vdc	Regen output is on, (optional external) regen resistor is dissipating energy
Drop-Out Voltage	+HV < 380 Vdc	Regen output is off, (optional external) regen resistor not dissipating energy
Tolerance	±2 Vdc	For either Cut-In or Drop-Out voltage

PROTECTIONS

HV Overvoltage	+HV > 400 Vdc	Drive PWM outputs turn off until +HV is less than overvoltage
HV Undervoltage	+HV < 60 Vdc	Drive PWM outputs turn off until +HV is greater than undervoltage
Drive over temperature	IGBT > 80 °C ±3 °C	Drive PWM outputs turn off until IGBT temperature is below threshold
Short circuits	Output to output, output to ground, internal PWM bridge faults	
I ² T Current limiting	Programmable: continuous current, peak current, peak time	
Motor over temperature	Programmable input to disable drive when voltage is above or below a set point 0~5 Vdc	
Feedback power loss	Fault occurs if feedback is removed or +5 V is <85% of normal	

MECHANICAL & ENVIRONMENTAL

Size	9.24 x 5.42 x 3.59 [234.7 x 137.6 x 91.1] in[mm]
Weight	4.19 lb [1.90kg]
Ambient temperature	0 to +40 °C operating, -40 to +85 °C storage
Humidity	0% to 95%, non-condensing
Contaminants	Pollution degree 2
Vibration	2 g peak, 10~500 Hz (sine), IEC60068-2-6
Shock	10 g, 10 ms, half-sine pulse, IEC60068-2-27
Environment	IEC68-2: 1990

OPTIONS

XTL-FA-01 Edge Filter	One used for each motor output. A passive R-L-C filter that reduces capacitive coupling of PWM outputs to adjacent cabling by lengthening the rise/fall times and providing common-mode filtering of the PWM outputs. Typically used in systems that have servo drives operating near other cables carrying low-amplitude sensor or video signals. Further details on the XTL-RA-04 can be found in the <i>Xenus Regeneration Guide</i> on the Copley Controls web-site http://www.copleycontrols.com/Motion/pdf/Xenus_regen_guide-03-04.pdf
XTL-RA-04 Regen Resistor	Used when the regenerative energy from a moving load is greater than the absorption capacity of the internal regen resistor. 15 Ω, 65 W default continuous power, 400 W max continuous power 10 kW peak power, 1000 ms peak power time. Further details on the XTL-FA-01 can be found in the <i>XTL-FA-01 Edge Filter for Xenus User Guide</i> on the Copley Controls web-site: http://www.copleycontrols.com/Motion/pdf/Xenus-Filter.pdf

AGENCY STANDARDS CONFORMANCE

Standards and Directives

Functional Safety

IEC 61508-1:2010, IEC 61508-2:2010, IEC 61508-3:2010, IEC 61508-4: 2010 (SIL 3)
 Directive 2006/42/EC (Machinery)
 ISO 13849-1/Cor. 1:2009 (Cat 3, PL d)
 IEC 61800-5-2:2007 (SIL3)

(see the Xenus Plus Dual Axis STO Manual for further details)

Product Safety

Directive 2006/95/EC (Low Voltage)
 IEC 61800-5-1:2007

EMC

Directive 2004/108/EC (EMC)
 IEC 61800-3:2004/A1:2011

Restriction of the Use of Certain Hazardous Substances (RoHS)

Directive 2011/65/EU (RoHS II)

Approvals

UL and cUL recognized component to:

UL 61800-5-1, 1st Ed.

TÜV SÜD Functional Safety to:

IEC 61508-1:2010, IEC 61508-2:2010, IEC 61508-3:2010, IEC 61508-4: 2010 (SIL 3)
 ISO 13849-1/Cor. 1:2009 (Cat 3, PL d)



16-01418 Document Revision History

Revision	Date	Remarks
00	March 3, 2016	Initial released version

FEEDBACK: XP2-230-20

FEEDBACK

Incremental:

Digital Incremental Encoder	Quadrature signals, (A, /A, B, /B, X, /X), differential (X, /X Index signals not required) 5 MHz maximum line frequency (20 M counts/sec) MAX3097 differential line receiver with 121 Ω terminating resistor between complementary inputs
Analog Incremental Encoder	Sin/cos format (sin+, sin-, cos+, cos-), differential, 1 Vpeak-peak, ServoTube motor compatible, BW > 300 kHz, 121 Ω terminating resistor between complementary inputs
Analog Index signal	Differential, 121 Ω terminating resistor between complementary inputs, 1 Vpeak-peak zero-crossing detect
Panasonic Incremental A Format	
Sanyo Denki Wire-saving Incremental	

Absolute:

*SERIAL ENCODERS MAY CONNECT TO THE FEEDBACK CONNECTORS OR THE MULTI-PORT
TWO SERIAL ENCODERS ARE THE MAXIMUM ALLOWED
TWO SERIAL ENCODERS ON ONE AXIS ARE NOT SUPPORTED*

SSI	Clock (X, /X), Data (S, /S) signals, 4-wire, clock output from XP2, data returned from encoder
EnDAT	Clock (X, /X), Data (S, /S), sin/cos (sin+, sin-, cos+, cos-) signals
Absolute A, Tamagawa Absolute A, Panasonic Absolute A Format, Sanyo Denki Absolute A	SD+, SD- (S, /S) signals, 2.5 or 4 MHz, 2-wire half-duplex communication Position feedback: 13-bit resolution per rev, 16 bit revolution counter (29 bit absolute position data) Status data for encoder operating conditions and errors
BiSS (B&C)	MA+, MA- (X, /X), SL+, SL- (S, /S) signals, 4-wire, clock output from XP2, data returned from encoder

DIGITAL HALLS

Type	Digital, single-ended, 120° electrical phase difference between U-V-W signals, Schmitt trigger, 1 μs RC filter, 24 Vdc compatible, programmable pull-up/down to +5 Vdc/ground, Vt+ = 2.5~3.5 Vdc, VT- = 1.3~2.2 Vdc, VH = 0.7~1.5 Vdc
Inputs	10 kΩ pullups to +5 Vdc, 1 μs RC filter to Schmitt trigger inverters

MULTI-MODE ENCODER PORT

As Input	Digital quadrature encoder (A, /A, B, /B, X, /X), 121 Ω terminating resistors between A & /A, B & /B inputs 18 M-counts/sec, post-quadrature (4.5 M-lines/sec)
As Emulated Output	Digital absolute encoder (Clk, /Clk, Dat, /Dat) half or full-duplex operation, 121 Ω terminating resistors Quadrature encoder emulation with programmable resolution to 4096 lines (65,536 counts) per rev from analog sin/cos encoders
As Buffered Output	A, /A, B, /B, outputs from MAX3032 differential line driver, X, /X, S, /S outputs from MAC3362 drivers Digital encoder feedback signals from primary digital encoder are buffered by MAX3032 line driver

ENCODER POWER SUPPLIES

Number	4, two on the feedback connectors (J10, J11), two on the control connector (J12) for the A and B multi-mode ports
Ratings	+5 Vdc @ 500 mA, thermal and overload protected, each output. 2000 mA total for all four outputs)

FEEDBACK: XP2-230-20-R

RESOLVER

Type	Brushless, single-speed, 1:1 to 2:1 programmable transformation ratio
Resolution	14 bits (equivalent to a 4096 line quadrature encoder)
Reference frequency	8.0 kHz
Reference voltage	2.8 Vrms, auto-adjustable by the drive to maximize feedback
Reference maximum current	100 mA
Maximum RPM	10,000+
Sin/Cos inputs	Differential, 54k ±1% differential impedance, 2.0 Vrms, BW ≥ 300 kHz

DIGITAL HALLS

Type	Digital, single-ended, 120° electrical phase difference between U-V-W signals, Schmitt trigger, 1 μs RC filter, 24 Vdc compatible, programmable pull-up/down to +5 Vdc/ground, Vt+ = 2.5~3.5 Vdc, VT- = 1.3~2.2 Vdc, VH = 0.7~1.5 Vdc
Inputs	10 kΩ pullups to +5 Vdc, 1 μs RC filter to Schmitt trigger inverters

MULTI-MODE ENCODER PORT

As Input	Digital quadrature encoder (A, /A, B, /B, X, /X), 121 Ω terminating resistors between A & /A, B & /B inputs 18 M-counts/sec, post-quadrature (4.5 M-lines/sec)
As Emulated Output	Digital absolute encoder (Clk, /Clk, Dat, /Dat) half or full-duplex operation, 121 Ω terminating resistors (See above for listing of absolute encoder types. EnDat Sin/Cos signals are not supported) Quadrature encoder emulation with programmable resolution to 4096 lines (65,536 counts) per rev from resolver, A, /A, B, /B, outputs from MAX3032 differential line driver, X, /X, S, /S outputs from MAC3362 drivers

ENCODER POWER SUPPLIES

Number	4, two on the feedback connectors (J10, J11), two on the control connector (J12) for the A and B multi-mode ports
Ratings	+5 Vdc @ 500 mA, thermal and overload protected, each output. 2000 mA total for all four outputs)

CANOPEN COMMUNICATIONS

Xenus uses the CAN physical layer signals CANH, CANL, and GND for connection, and CANopen protocol for communication. Before installing the drive in a CAN system, it must be assigned a CAN address. A maximum of 127 CAN nodes are allowed on a single CAN bus. The rotary switch on the front panel controls the four lower bits of the seven-bit CAN address. When the number of nodes on a bus is less than sixteen, the CAN address can be set using only the switch. For installations with sixteen or more CAN nodes on a network CME 2 can be used to configure Xenus to use the rotary switch, or combinations of digital inputs and programmed offset in flash memory to configure the drive with a higher CAN node address. For more information on CANopen communications, download the CANopen Manual from the Copley web-site: <http://www.copleycontrols.com/motion/downloads/pdf/CANopenProgrammersManual.pdf>

CANOPEN CONNECTORS

Dual RJ-45 connectors that accept standard Ethernet cables are provided for CAN bus connectivity. Pins are wired-through so that drives can be daisy-chained and controlled with a single connection to the user's CAN interface. A CAN terminator should be placed in the last drive in the chain. The XP2-NK connector kit provides a D-Sub adapter that plugs into a CAN controller and has an RJ-45 socket that accepts the Ethernet cable.

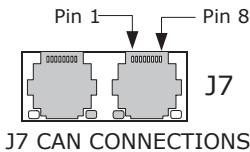

NET (CAN STATUS) LED

A bi-color LED gives the state of the CAN connection in accordance with the CAN-CiA specification 303, part 3. The green (RUN) LED shows the state of the CANopen state machine. The red (ERR) LED shows the occurrence of errors (sync, guard, or heartbeat) and of the CAN bus physical layer. During a reset condition, the green LED will be off. In operation, the red & green colors will alternate with the number of blinks or on/off condition shown in the table to the right.

Note: Red & green led on-times do not overlap. LED color may be red, green, off, or flashing of either color.

XP2-NK CAN CONNECTOR KIT

The kit contains the XP2-CV adapter that converts the CAN interface D-Sub 9M connector to an RJ-45 Ethernet cable socket, plus a 10 ft (3 m) cable and terminator. Both connector pin-outs conform to the CiA DR-303-1 specification.

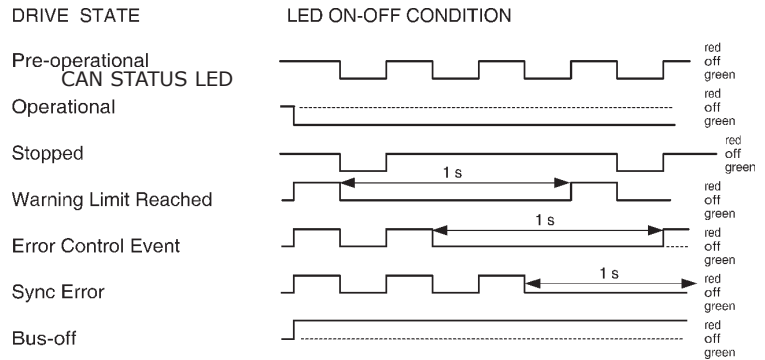
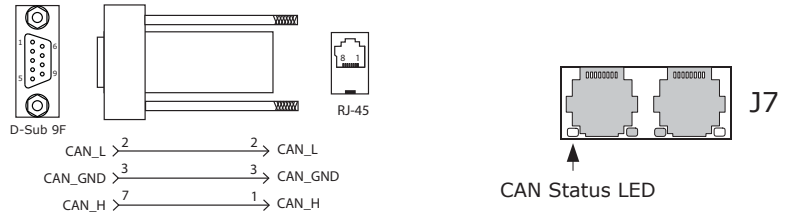

Note: Red & green led on-times do not overlap. LED color may be red, green, off, or flashing of either color.

CAN NETWORK NODE-ID (ADDRESS)

In an CANopen network, nodes are assigned addresses 1~127. Address 0 is reserved for the CAN bus master. In the XPL, the node address is provided by two 16-position rotary switches with hexadecimal encoding. These can set the address of the drive from 0x01~0x7F (1~127 decimal). The chart shows the decimal values of the hex settings of each switch.

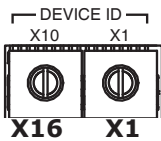

Node-ID (Address) Switches

To find the Node-ID given the switch settings:
 Node-ID = (S1 * 16) + S2
 Example: S1 = 5, S2 = B
 S1 value = (5*16) = 80, S2 value = Hex(B) = 11,
 Node-ID = 80 + 11 = 91

To find the switch settings for a given address:
 S1 = The integer part of (Node-ID / 16)
 S2 = Hex (Node-ID - (S1 * 16))
 Example: Node-ID = 91
 S1 = 91/16 = 5.69, integer part = 5, (5*16) = 80
 S2 = Hex (91 - 80) = 11 = 0xB

	S1	S2
HEX	DEC	
0	0	0
1	16	1
2	32	2
3	48	3
4	64	4
5	80	5
6	96	6
7	112	7
8	Not Used for CAN Addr	8
9		9
A		10
B		11
C		12
D		13
E		14
F		15



CME2 -> Amplifier -> Network Configuration

COMMUNICATIONS: RS-232 SERIAL

XP2 is configured via a three-wire, full-duplex DTE RS-232 port that operates from 9600 to 115,200 Baud, 8 bits, no parity, and one stop bit. Signal format is full-duplex, 3-wire, DTE using RxD, TxD, and Gnd. Connections to the XP2 RS-232 port are through J7, an RJ-11 connector. The XP2 Serial Cable Kit (SER-CK) contains a modular cable, and an adapter that connects to a 9-pin, Sub-D serial port connector (COM1, COM2, etc.) on PC's and compatibles.

SER-CK SERIAL CABLE KIT

The SER-CK provides connectivity between a D-Sub 9 male connector and the RJ-11 connector on the XP2. It includes an adapter that plugs into the COM1 (or other) port of a PC and uses common modular cable to connect to the XP2. The connections are shown in the diagram below.

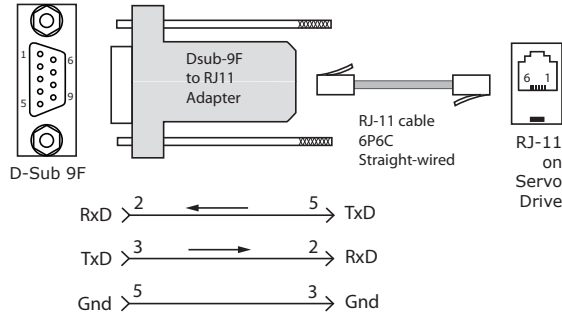

J6: RS-232 PORT

RJ-11 receptacle, 6 position, 4 contact

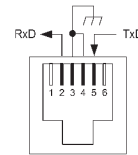

PIN	SIGNAL
2	RxD
3,4	Gnd
5	TxD



Don't forget to order a Serial Cable Kit SER-CK when placing your order for an XP2!

ASCII COMMUNICATION PROTOCOL

ASCII COMMUNICATIONS

The Copley ASCII Interface is a set of ASCII format commands that can be used to operate and monitor Copley Controls Accelnet, Stepnet, and Xenus series amplifiers over an RS-232 serial connection. For instance, after basic amplifier configuration values have been programmed using CME 2, a control program can use the ASCII Interface to:

- Enable the amplifier in Programmed Position mode.
- Home the axis.
- Issue a series of move commands while monitoring position, velocity, and other run-time variables.

Additional information can be found in the ASCII Programmers Guide on the Copley website:

http://www.copleycontrols.com/Motion/pdf/ASCII_ProgrammersGuide.pdf

RS-232 MULTI-DROP

The RS-232 specification makes no allowance for more than two devices on a serial link. But, multiple Xenus drives can communicate over a single RS-232 port by daisy-chaining a master drive to other drives using CAN cables. In the CAN protocol, address 0 is reserved for the CAN master and thereafter all other nodes on a CAN network must have unique, non-zero addresses. When the Xenus CAN address is set to 0, it acts as a CAN master, converting the RS-232 data into CAN messages and passing it along to the other drives which act as CAN nodes.

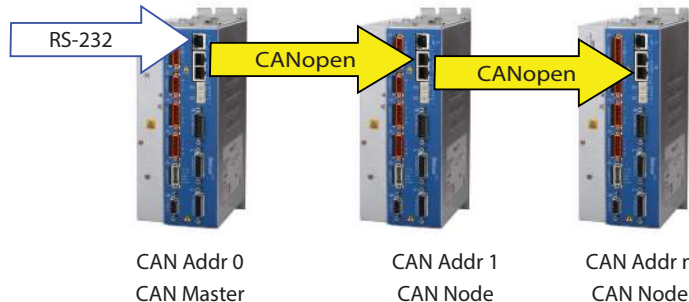

For Serial-multi-drop you'll need an Serial Cable Kit SER-CK plus CANopen network cables to connect the drives as shown. The XP2-NC-01 and XP2-NC-10 are 1 ft (0.3m) and 10 ft (3m) cables that will do the job.

SAFE TORQUE OFF (STO)

DESCRIPTION

The XP2 provides the Safe Torque Off (STO) function as defined in IEC 61800-5-2. Three opto-couplers are provided which, when de-energized, prevent the upper and lower devices in the PWM outputs from being operated by the digital control core. This provides a positive OFF capability that cannot be overridden by the control firmware, or associated hardware components. When the opto-couplers are activated (current is flowing in the input diodes), the control core will be able to control the on/off state of the PWM outputs.

INSTALLATION

 DANGER	Refer to the Xenus Plus Dual-Axis STO User Manual
	The information provided in the Xenus Plus Dual-Axis STO User Manual must be considered for any application using the XP2 drive's STO feature. Failure to heed this warning can cause equipment damage, injury, or death.

STO BYPASS (MUTING)

In order for the PWM outputs of the XP2 to be activated, current must be flowing through all of the opto-couplers that are connected to the STO-1 and STO-2 terminals of J6, and the drive must be in an ENABLED state. When the opto-couplers are OFF, the drive is in a Safe Torque Off (STO) state and the PWM outputs cannot be activated by the control core to drive a motor. This diagram shows connections that will energize all of the opto-couplers from an internal current-source. When this is done the STO feature is overridden and control of the output PWM stage is under control of the digital control core.

If not using the STO feature, these connections must be made in order for the XP2 to be enabled.

STO BYPASS CONNECTIONS

Note: STO applies to Axis-A AND Axis-B



Current must flow through all of the opto-couplers before the XP2 can be enabled

* STO bypass connections on the XP2 and Xenus XPL models are different. If both drives are installed in the same cabinet, the diode should be wired as shown to prevent damage that could occur if the STO bypass connectors are installed on the wrong drive. The diode is not required for STO bypass on the XP2 and can be replaced by a wire between pins 7 and 9.

Bypass Plug Connections
 Jumper pins:
 2-4, 3-5, 6-8, 7-9 *

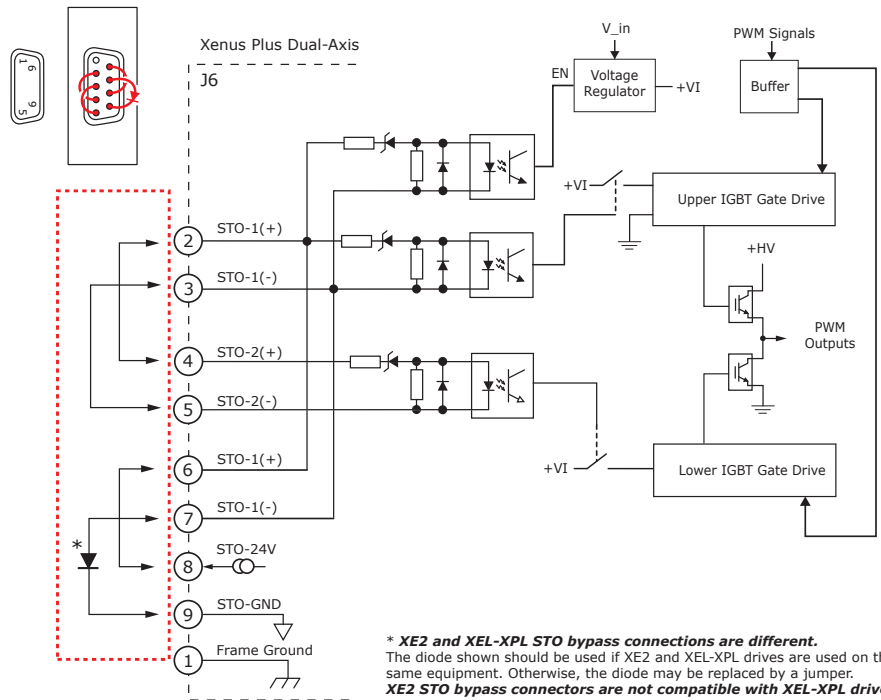

*** XE2 and XEL-XPL STO bypass connections are different.**
 The diode shown should be used if XE2 and XEL-XPL drives are used on the same equipment. Otherwise, the diode may be replaced by a jumper.
XE2 STO bypass connectors are not compatible with XEL-XPL drives.

SAFETY CONNECTOR J6

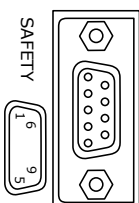

J6 SIGNALS

PIN	SIGNAL	PIN	SIGNAL
1	Frame Gnd	6	STO-1(+)
2	STO-1(+)	7	STO-1(-)
3	STO-1(-)	8	STO-24V
4	STO-2(+)	9	STO-GND
5	STO-2(-)		

HIGH SPEED INPUTS: IN2, IN3, IN4, IN5, IN12, IN13, IN14, IN15

DIGITAL POSITION

Digital position commands can be in either single-ended or differential format. Single-ended signals should be sourced from devices with active pull-up and pull-down to take advantage of the high-speed inputs. Differential inputs have 121 Ω line-terminators.

SINGLE-ENDED PULSE & DIRECTION

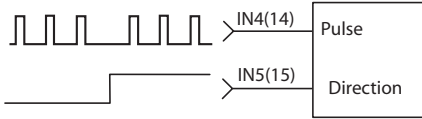

DIFFERENTIAL PULSE & DIRECTION

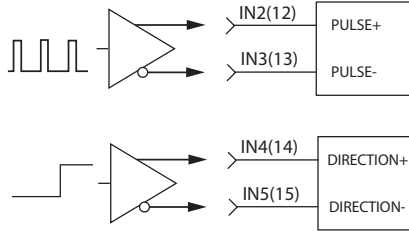

COMMAND SINGLE-ENDED

Signal	Axis A	Axis B
Pls, Enc A	J12-10	J12-15
Dir, Enc B	J12-11	J12-30
Sgnd	J12-6,16,22,31,37,44	
Shld	J12-1	

SINGLE-ENDED CU/CD

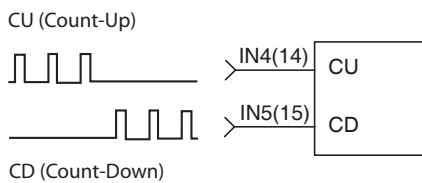

DIFFERENTIAL CU/CD

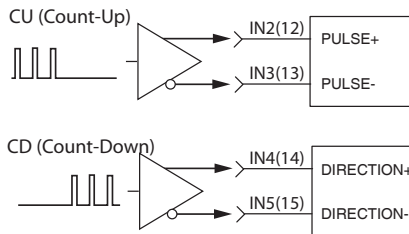

COMMAND DIFFERENTIAL

Signal	Axis A	Axis B
Pls, Enc A	J12-8	J12-13
/Pls, Enc /A	J12-9	J12-14
Dir, Enc B	J12-10	J12-15
/Dir, Enc /B	J12-11	J12-30
Sgnd	J12-6,16,22,31,37,44	
Shld	J12-1	

QUAD A/B ENCODER SINGLE-ENDED

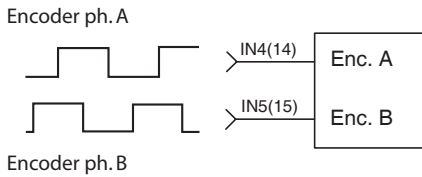

QUAD A/B ENCODER DIFFERENTIAL

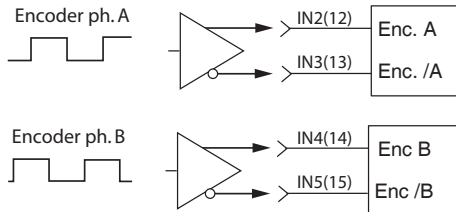

DIGITAL TORQUE, VELOCITY

Digital torque or velocity commands can be in either single-ended or differential format. Single-ended signals must be sourced from devices with active pull-up and pull-down to take advantage of the high-speed inputs.

SINGLE-ENDED PWM & DIRECTION

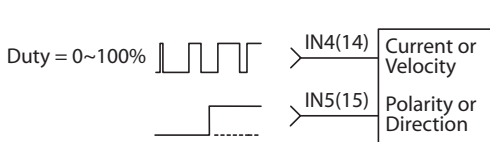

DIFFERENTIAL PWM & DIRECTION

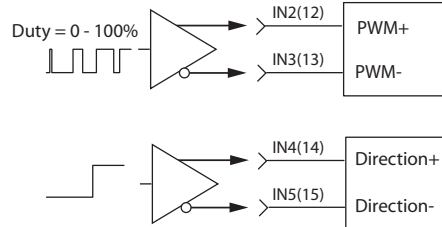

COMMAND SINGLE-ENDED

Signal	Axis A	Axis B
PWM	J12-10	J12-15
Dir	J12-11	J12-30
Sgnd	J12-6,16,22,31,37,44	
Shld	J12-1	

SINGLE-ENDED 50% PWM

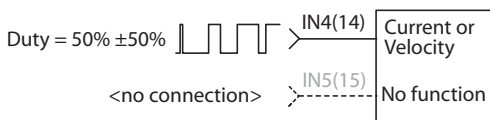

DIFFERENTIAL 50% PWM

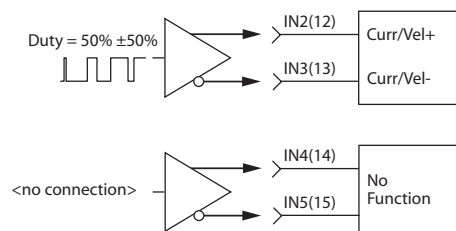

COMMAND DIFFERENTIAL

Signal	Axis A	Axis B
PWM	J12-8	J12-13
/PWM	J12-9	J12-14
Dir	J12-10	J12-15
/Dir	J12-11	J12-30
Sgnd	J12-6,16,22,31,37,44	
Shld	J12-1	

MULTI-MODE ENCODER PORT AS AN INPUT

INPUT TYPES

POSITION COMMAND INPUTS: DIFFERENTIAL

- Pulse & Direction
- CW & CCW (Clockwise & Counter-Clockwise)
- Encoder Quad A & B
- Camming Encoder A & B input

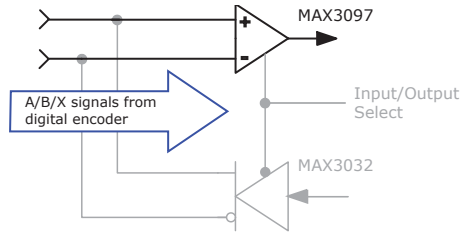

COMMAND INPUT MULTI-PORT

Signal	Axis A	Axis B
Pls, Enc A	J12-36	J12-42
/Pls, Enc /A	J12-21	J12-27
Dir, Enc B	J12-35	J12-41
/Dir, Enc /B	J12-20	J12-26
Enc X	J12-34	J12-40
Enc /X	J12-19	J12-25
Sgnd	J12-6,16,22,31,37,44	
Shld	J12-1	

CURRENT or VELOCITY COMMAND INPUTS: DIFFERENTIAL

- Current or Velocity & Direction
- Current or Velocity (+) & Current or Velocity (-)

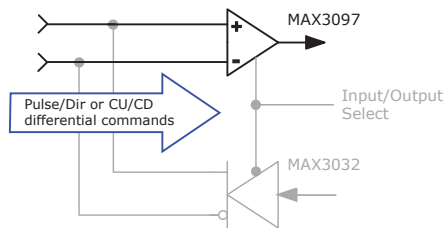

SECONDARY FEEDBACK: INCREMENTAL

- Quad A/B/X incremental encoder
- Quad A/B emulated encoder from sin/cos encoder

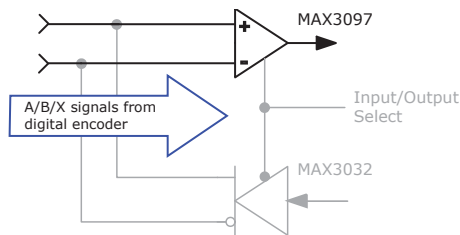

SECONDARY FEEDBACK: ABSOLUTE

- S channel: Absolute A encoders (2-wire)
The S channel first sends a Clock signal and then receives Data from the encoder in half-duplex mode.
- S & X channels: SSI, BiSS, EnDat encoders (4-wire)
The X channel sends the Clock signal to the encoder, which initiates data transmission from the encoder on the S-channel in full-duplex mode

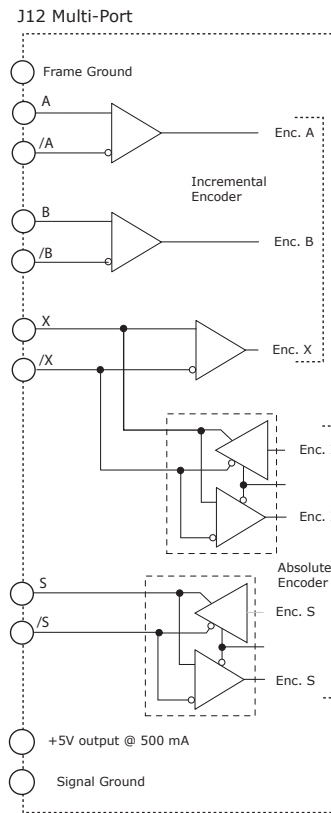
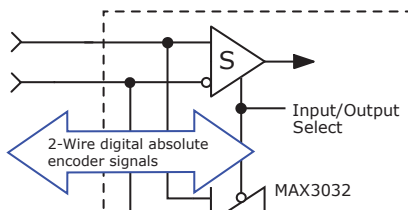

EMULATED QUAD A/B/X MULTI-PORT

Signal	Axis A	Axis B
Enc A	J12-36	J12-42
Enc /A	J12-21	J12-27
Enc B	J12-35	J12-41
Enc /B	J12-20	J12-26
Enc X	J12-34	J12-40
Enc /X	J12-19	J12-25
Sgnd	J12-6,16,22,31,37,44	
Shld	J12-1	

GENERAL PURPOSE INPUTS

HS Inputs [IN1~2]
24 Vdc max

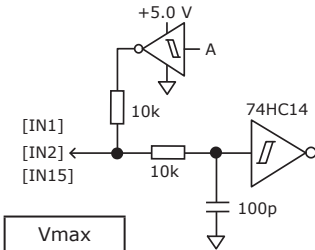

Vmax
+5V
±10
+12V
+24V
±24V

Input	Pin	R1	R2	C1	Vm	Input	Pin	R1	R2	C1	Vm
*IN1	J12-7	10k	10k	100p	+24	*IN11	J12-12	10k	10k	100p	+24
*IN2	J12-8	10k	1k	100p	+12	*IN12	J12-13	10k	1k	100p	+12
*IN3	J12-9					*IN13	J12-14				
*IN4	J12-10					*IN14	J12-15				
*IN5	J12-11					*IN15	J12-30				
IN6	J9-2					Opto	±24				
IN7	J9-3	IN17	J9-8								
IN8	J9-4	IN18	J9-9								
IN9	J9-5	IN19	J9-18								
ICOM1	J9-6	ICOM2	J9-17								
IN10	J10-7	4.99k	10k	33n	+24			IN20	J11-7	4.99k	10k
IN21	J10-24	10k	10k	100p		IN22	J11-24	10k	10k	100p	

* PROGRAMMABLE PULL UP/DOWN

The input resistor of these inputs is programmable to pull-up to +5V or pull-down to 0V. Pull-up is the default and works with current-sinking outputs from a controller. Pull-down works with current-sourcing outputs, typically PLC's that drive grounded loads. Six of the inputs have individually settable PU/PD. The other four have PU/PD control for pairs of inputs.

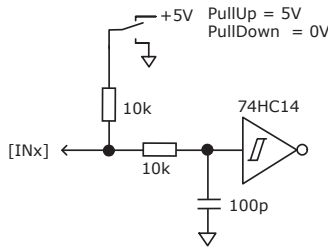

INPUTS WITH PROGRAMMABLE PULL UP/DOWN

Input	Pin	PU/PD	Input	Pin	PU/PD
IN1	J12-7	1	IN11	J12-12	5
IN2	J12-8	2	IN12	J12-13	6
IN3	J12-9	3	IN13	J12-14	7
IN4	J12-10	4	IN14	J12-15	8
IN5	J12-11		IN15	J12-30	

[IN2~5,12~15] SIGNALS

S.E. Input	Diff Input	Pin	S.E. Input	Diff Input	Pin
IN2	IN2+	J12-8	IN12	IN12+	J12-13
IN3	IN2-	J12-9	IN13	IN12-	J12-14
IN4	IN4+	J12-10	IN14	IN14+	J12-15
IN5	IN4-	J12-11	IN15	IN14-	J12-30

SINGLE-ENDED/DIFFERENTIAL DIGITAL INPUTS [IN2~5,12~15]

These inputs have all the programmable functions of the GP inputs plus these additional functions which can be configured as single-ended (SE) or differential (DIFF):

- PWM 50%, PWM & Direction for Velocity or Current modes
- Pulse/Direction, CU/CD, or A/B Quad encoder inputs for Position or Camming modes

SINGLE-ENDED
12 Vdc max

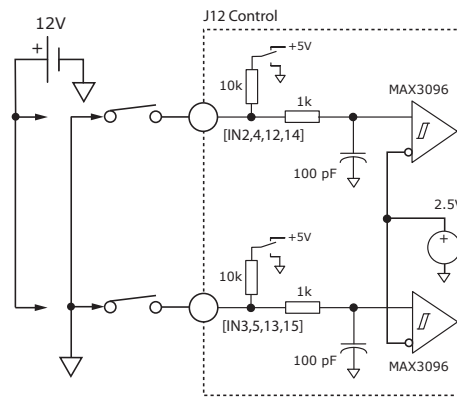

DIFFERENTIAL
12 Vdc max

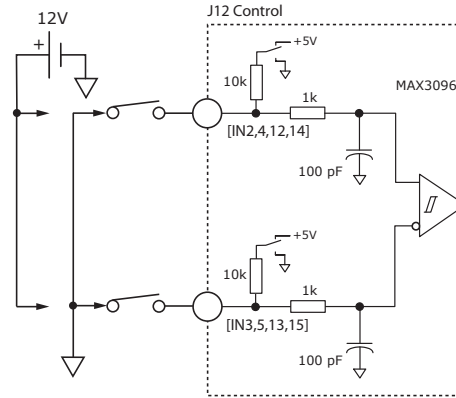

PLC outputs are frequently current-sourcing from 24V for driving grounded loads. PC based digital controllers commonly use NPN or current-sinking outputs. Set the Xenus inputs to pull-down to ground for current-sourcing connections, and to pull-up to 5V for current-sinking connections.

OPTO-ISOLATED INPUTS: IN6, IN7, IN8, IN9, IN16, IN17, IN18, IN19

These inputs have all the programmable functions of the GP inputs plus opto-isolation. There are two groups of four inputs, each with its own common terminal. Grounding the common terminal configures the inputs to work with current-sourcing outputs from controllers like PLC's. When the common terminal is connected to +24V, then the inputs will be activated by current-sinking devices such as NPN transistors or N-channel MOSFETs. The minimum ON threshold of the inputs is ± 15 Vdc.

IN THE GRAPHICS BELOW, "24V" IS FOR CONNECTIONS TO CURRENT-SOURCING OUTPUTS AND "GND" IS FOR CURRENT-SINKING OUTPUTS ON THE CONTROL SYSTEM

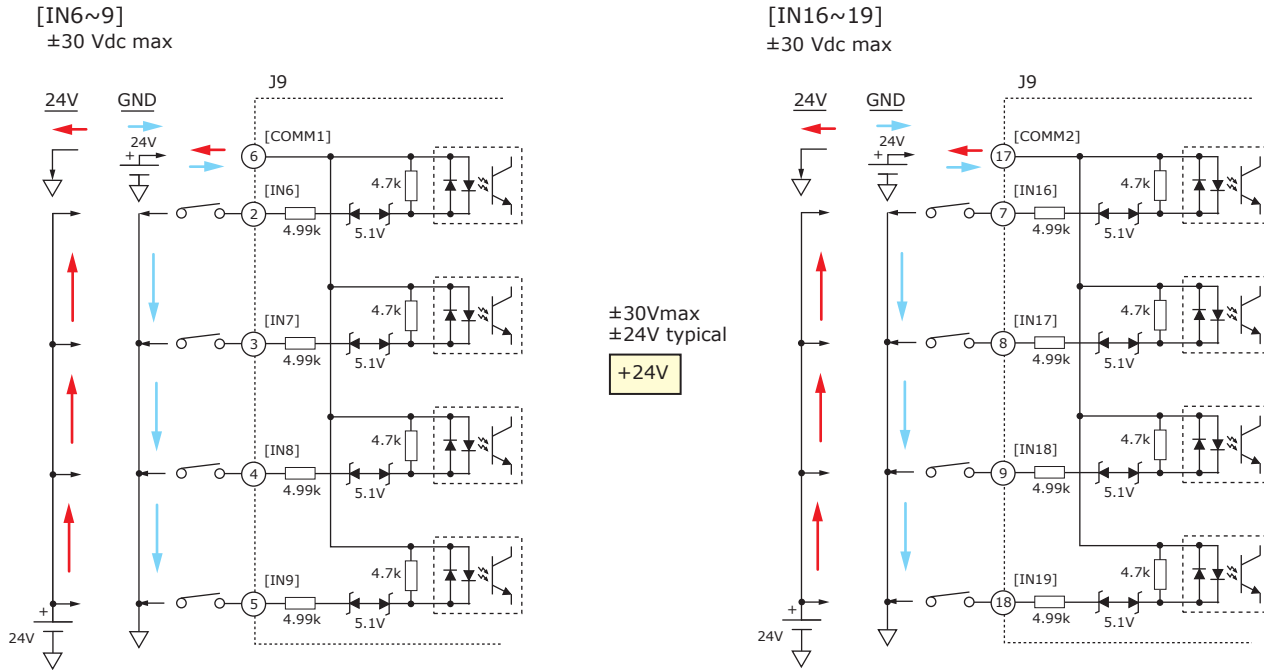

These inputs work with current-sourcing OR current-sinking connections. Connect the COMM to controller ground/common for current-sourcing connections and to 15~24V from the controller for current-sinking connections.

[IN6~9,16~19] SIGNALS

Signal	Pins	Signal	Pins
IN6	J9-2	IN16	J9-7
IN7	J9-3	IN17	J9-8
IN8	J9-4	IN18	J9-9
IN9	J9-5	IN19	J9-18
COMM1	J9-6	COMM2	J9-17

ANALOG INPUTS

The analog inputs have a ± 10 Vdc range at 14-bit resolution
 As reference inputs they can take position/velocity/torque commands from a controller. If not used as command inputs, they can be used as general-purpose analog inputs.

[AIN A,B] SIGNALS

Signal	Axis A	Axis B
AIN(+)	J12-3	J12-5
AIN(-)	J12-2	J12-4
Sgnd	J12-6,16,22,31,37,44	
Shield	J12-1	

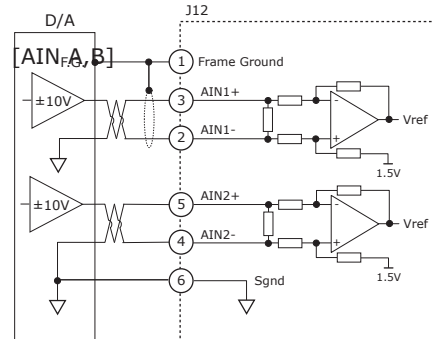

ISOLATED GENERAL PURPOSE OUTPUTS OUT1~5

- Digital, opto-isolated
- SSR, 2-terminal
- Flyback diode for inductive loads
- 24V Compatible
- Programmable functions

[OUT1~5] SIGNALS

Signal	Pins	Signal	Pins
[OUT1+]	J9-19	[OUT1-]	J9-10
[OUT2+]	J9-20	[OUT2-]	J9-11
[OUT3+]	J9-21	[OUT3-]	J9-12
[OUT4+]	J9-22	[OUT4-]	J9-13
[OUT5+]	J9-23	[OUT5-]	J9-14

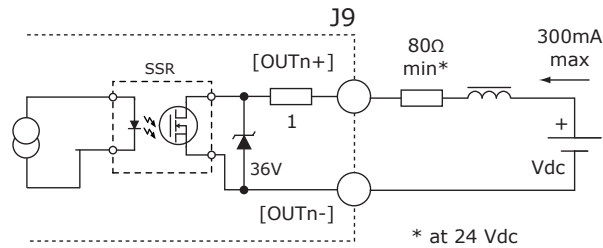

HI/LO DEFINITIONS: [OUT1~5]

Input	State	Condition
OUT1~5	HI	Output transistor is ON, current flows
	LO	Output transistor is OFF, no current flows

± 30 Vmax
 ± 24 V typical
+24V

30 Vdc max

Zener clamping diodes across outputs allow driving of resistive-inductive (R-L) loads without external flyback diodes.

ISOLATED BRAKE OUTPUTS

- Brake outputs Opto-isolated
- Flyback diodes for inductive loads
- 24V Compatible
- Connection for external 24V power supply
- Programmable functions

SPECIFICATIONS

Output	Data	Notes
Voltage Range	Max	+30 Vdc
Output Current	Ids	1.0 Adc

HI/LO DEFINITIONS: OUTPUTS

Input	State	Condition
BRK-A,B OUT6,7	HI	Output transistor is OFF Brake is un-powered and locks motor Motor cannot move Brake state is Active
	LO	Output transistor is ON Brake is powered, releasing motor Motor is free to move Brake state is NOT-Active

CME2 Default Setting for Brake Outputs [OUT6,7] is "Brake - Active HI"
Active = Brake is holding motor shaft (i.e. the *Brake is Active*)

- Motor cannot move
- No current flows in coil of brake
- CME2 I/O Line States shows Output 6 or 7 as HI
- BRK Output voltage is HI (24V), MOSFET is OFF
- Servo drive output current is zero
- Servo drive is disabled, PWM outputs are off

Inactive = Brake is not holding motor shaft (i.e. the *Brake is Inactive*)

- Motor can move
- Current flows in coil of brake
- CME2 I/O Line States shows Output 6 or 7 as LO
- BRK output voltage is LO (~0V), MOSFET is ON
- Servo drive is enabled, PWM outputs are on
- Servo drive output current is flowing

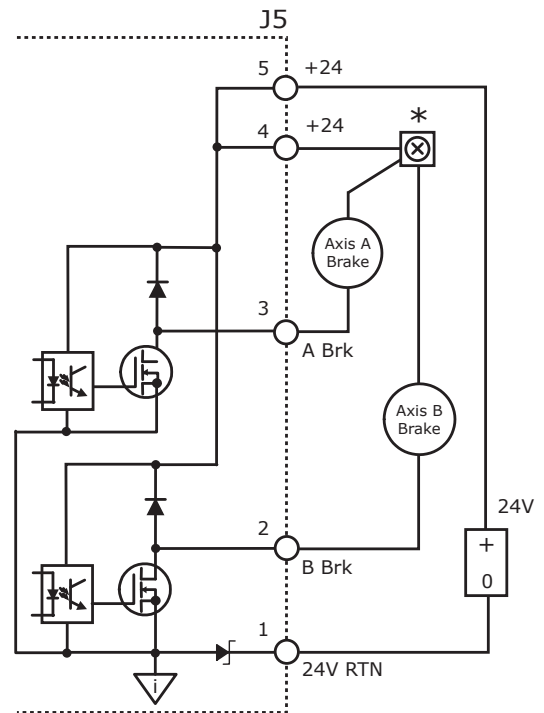

The brake circuits are optically isolated from all drive circuits and frame ground.

CONNECTIONS

Pin	Signal
5	+24V
4	+24V
3	A Brk [OUT6]
2	B Brk [OUT7]
1	24V Return

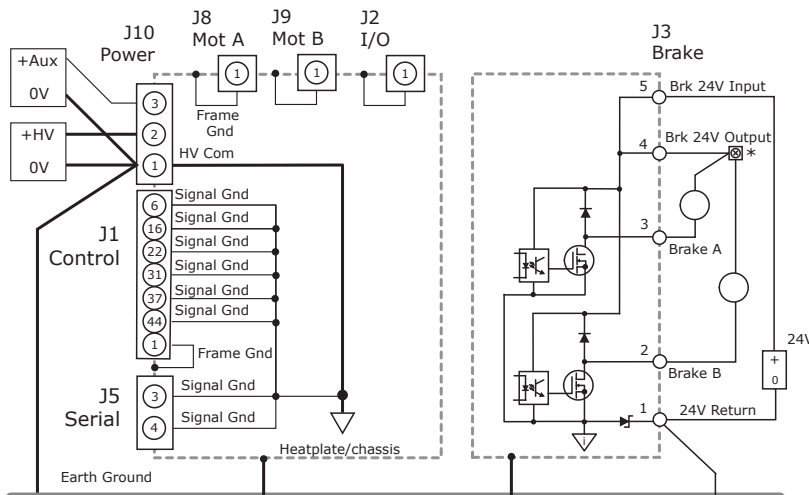

Earthing connections for power supplies should be as close as possible to eliminate potential differences between power supply 0V terminals.

This diagram shows the connections to the drive that share a common ground in the driver. If the brake 24V power supply is separate from the DC supply powering the drive, it is important that it connects to an earth or common grounding point with the HV power supply.

MOTOR CONNECTIONS: ENCODER & RESOLVER

Motor connections are of three types: phase, feedback, and thermal sensor. The phase connections carry the drive output currents that drive the motor to produce motion. A thermal sensor that indicates motor overtemperature is used to shut down the drive to protect the motor. Feedback can be digital quad A/B encoder, analog sin/cos encoder, resolver or digital Halls, depending on the version of the drive.

QUAD A/B ENCODER WITH FAULT PROTECTION

Encoders with differential line-driver outputs are required (single-ended encoders are not supported) and provide incremental position feedback via the A/B signals and the optional index signal (X) gives a once per revolution position mark. The MAX3097 receiver has differential inputs with fault protections for the following conditions:

- Short-circuits line-line:* This produces a near-zero voltage between A & /A which is below the differential fault threshold.
- Open-circuit condition:* The 121Ω terminator resistor will pull the inputs together if either side (or both) is open. This will produce the same fault condition as a short-circuit across the inputs.
- Low differential voltage detection:* This is possible with very long cable runs and a fault will occur if the differential input voltage is < 200mV.
- ±15kV ESD protection:* The 3097E has protection against high-voltage discharges using the Human Body Model.
- Extended common-mode range:* A fault occurs if the input common-mode voltage is outside of the range of -10V to +13.2V

CONNECTIONS WITH A/B/X ENCODER*

A/B/X SIGNALS

CONNECTIONS WITH NO INDEX SIGNAL*

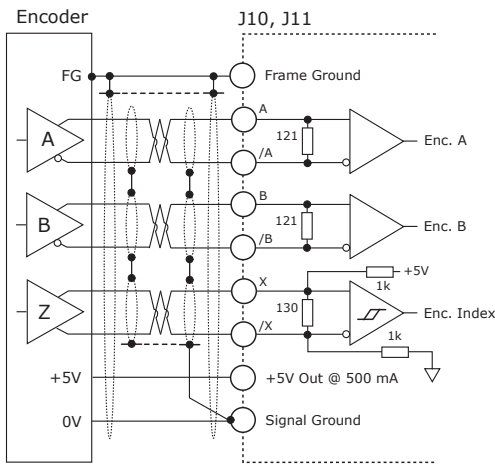

Signal	J10,J11 Pin
Enc A	13
Enc /A	12
Enc B	11
Enc /B	10
Enc X	9
Enc /X	8
+5V	6
Sgnd	5
Shld	1

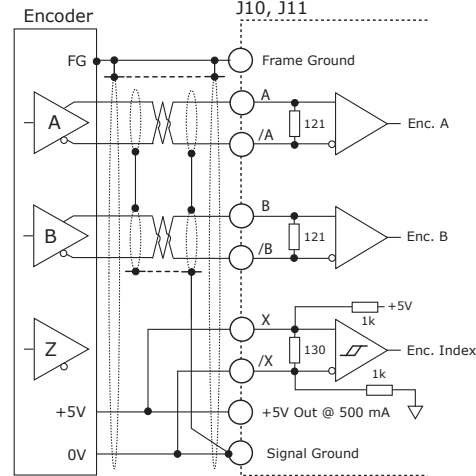

SHIELDED CABLE CONNECTIONS

Double-shielded cable is recommended for resolvers and analog sin/cos encoders. The outer shield connects to the motor and drive frames. The inner shield(s) should only connect to the Signal Ground at the drive. The inner shields shown here are for individually shielded twisted-pair cables. If the inner shield is a single one, it connects to Signal Ground at the drive. The inner shield should have no connection at the motor, or the the outer shield. Double-shielding is used less frequently for digital encoders, but the connections are shown here and on following pages for completeness.

ANALOG SIN/COS INCREMENTAL ENCODER**

The sin/cos/idx inputs are differential with 121 Ω terminating resistors and accept 1 Vp-p signals in the format used by incremental encoders with analog outputs, or with [ServoTube](#) motors.

RESOLVER (XP2-230-20-R)

Resolver set up, motor phasing, and other commissioning adjustments are made with CME 2 software. There are no hardware adjustments.

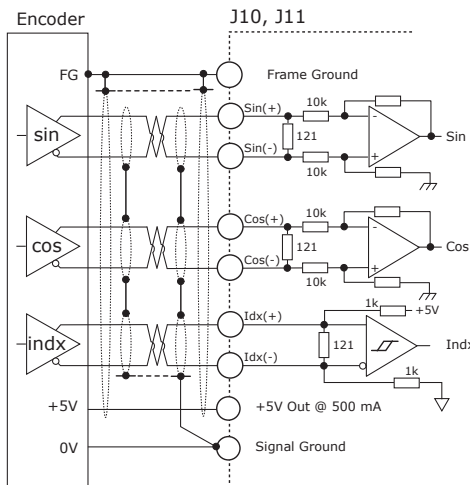

SIN/COS SIGNALS

Signal	J10,J11 Pin
Sin(+)	19
Sin(-)	18
Cos(+)	21
Cos(-)	20
Idx(+)	23
Idx(-)	22
+5V	17
Sgnd	16
Shld	1

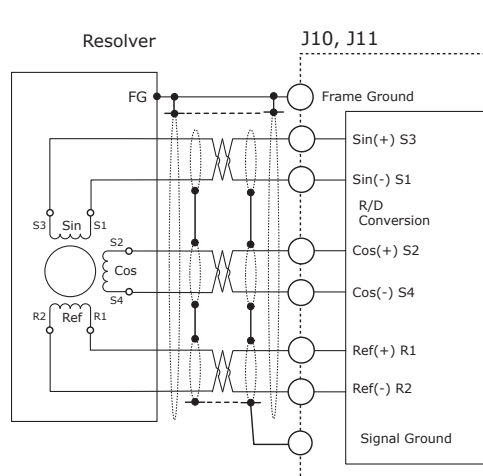

RESOLVER SIGNALS

Signal	J10,J11 Pin
Sin(+)	S3 19
Sin(-)	S1 18
Cos(+)	S2 21
Cos(-)	S4 20
Ref(+)	R1 23
Ref(-)	R2 22
+5V	17
Sgnd	16
Shld	1

Notes for XP2-230-20-R model:

- * These connections are not supported on J10 & J11. The Multi-Port on J12 can be programmed to accept these feedback types.
- ** Sin/Cos feedback is not supported.

MOTOR CONNECTIONS: ABSOLUTE ENCODERS

SSI ABSOLUTE ENCODER*

The SSI (Synchronous Serial Interface) is an interface used to connect an absolute position encoder to a motion controller or control system. The XEL drive provides a train of clock signals in differential format to the encoder which initiates the transmission of the position data on the subsequent clock pulses. The polling of the encoder data occurs at the current loop frequency (16 kHz). The number of encoder data bits and counts per motor revolution are programmable. The hardware bus consists of two signals: SCLK and SDATA. Data is sent in 8 bit bytes, LSB first. The SCLK signal is only active during transfers. Data is clocked out on the falling edge and clock in on the rising edge of the Master.

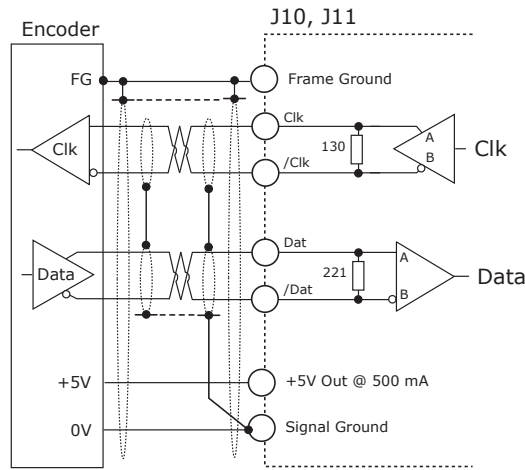

SSI, BiSS SIGNALS

Signal	J10, J11 Pin
Clk	9
/Clk	8
Data	15
/Data	14
+5V	6,17
Sgnd	5,16
Shld	1

BiSS ABSOLUTE ENCODER*

BiSS is an - Open Source - digital interface for sensors and actuators. BiSS refers to principles of well known industrial standards for Serial Synchronous Interfaces like SSI, AS-Interface® and Interbus® with additional options.

- Serial Synchronous Data Communication
- Cyclic at high speed
- 2 unidirectional lines Clock and Data
- Line delay compensation for high speed data transfer
- Request for data generation at slaves
- Safety capable: CRC, Errors, Warnings
- Bus capability incl. actuators
- Bidirectional
- BiSS B-protocol: Mode choice at each cycle start
- BiSS C-protocol: Continuous mode

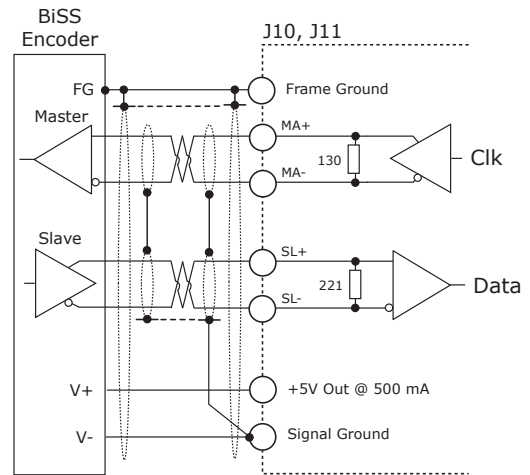

ENDAT ABSOLUTE ENCODER*

The EnDat interface is a Heidenhain interface that is similar to SSI in the use of clock and data signals, but which also supports analog sin/cos channels from the same encoder. The number of position data bits is programmable as is the use of sin/cos channels. Use of sin/cos incremental signals is optional in the EnDat specification.

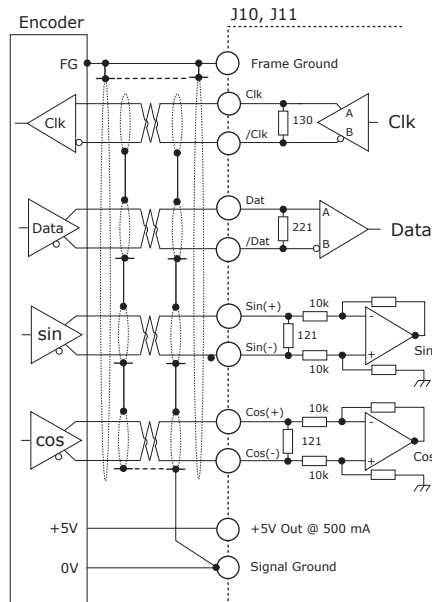

ENDAT SIGNALS

Signal	J10, J11 Pin
Clk	9
/Clk	8
Data	15
/Data	14
Sin(+)	19
Sin(-)	18
Cos(+)	21
Cos(-)	20
+5V	6,17
Sgnd	5,16
Shld	1

ABSOLUTE-A ENCODER & INCREMENTAL A*

The interface is a serial, half-duplex type that is electrically the same as RS-485.

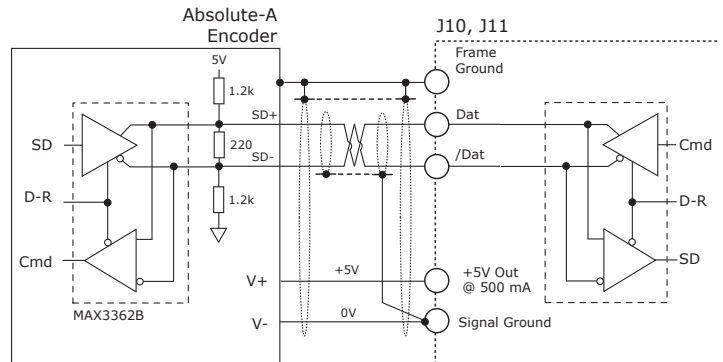

ABSOLUTE ENCODERS

- Absolute-A
- Tamagawa Absolute-A
- Panasonic Absolute A Format
- Sanyo Denki Absolute-A

INCREMENTAL ENCODERS

- Panasonic Incremental A

ABSOLUTE-A SIGNALS

Signal	J10, J11 Pin
Data	15
/Data	14
+5V	6,17
Sgnd	5,16
Shld	1

Notes for XP2-230-20-R model:

* These connections are not supported on J10 & J11. The Multi-Port on J12 can be programmed to accept these feedback types.

MOTOR CONNECTIONS: MOTOR, HALLS, OVERTEMP

MOTOR PHASE CONNECTIONS

The drive output is a three-phase PWM inverter that converts the DC buss voltage (+HV) into three sinusoidal voltage waveforms that drive the motor phase-coils. Cable should be sized for the continuous current rating of the motor. Motor cabling should use twisted, shielded conductors for CE compliance, and to minimize PWM noise coupling into other circuits. The motor cable shield should connect to motor frame and the drive frame ground terminal (J3,J4-1) for best results.

MOTOR SIGNALS

Signal	J3,J4 Pin
Mot U	4
Mot V	3
Mot W	2
Shield	1

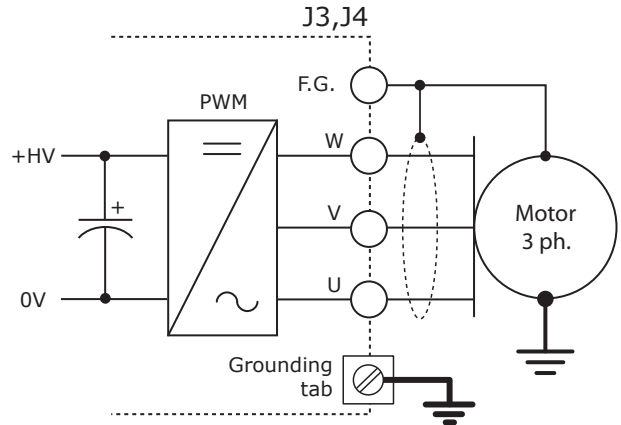

DIGITAL HALL SIGNALS

Hall signals are single-ended signals that provide absolute feedback within one electrical cycle of the motor. There are three of them (U, V, & W) and they may be sourced by magnetic sensors in the motor, or by encoders that have Hall tracks as part of the encoder disc. They typically operate at much lower frequencies than the motor encoder signals, and are used for commutation-initialization after startup, and for checking the motor phasing after the amplifier has switched to sinusoidal commutation.

HALL SIGNALS

Signal	J10,J11 Pin
Hall U	2
Hall V	3
Hall W	4
+5V	6,17
Sgnd	5,16,25,26

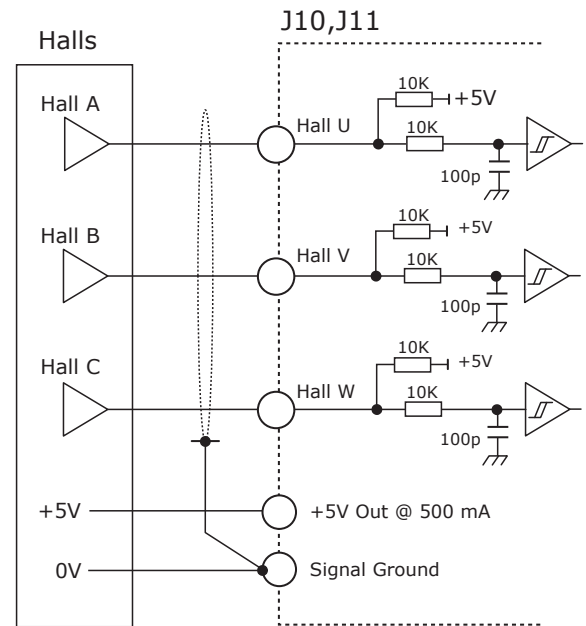

MOTEMP SIGNALS

Signal	Pin
Motemp A	J10-7
Motemp B	J11-7
Sgnd	J10,J11 -5,16,25,26

+30Vmax
+24V typical
+24V

Property	Ohms
Resistance in the temperature range 20°C to +70°C	60~750
Resistance at 85°C	≤1650
Resistance at 95°C	≥3990
Resistance at 105°C	≥12000

MOTOR OVER TEMP INPUT

The 4.99k pull-up resistor works with PTC (positive temperature coefficient) thermistors that conform to BS 4999:Part 111:1987 (table below), or switches that open/close indicating a motor over-temperature condition. The active level is programmable.

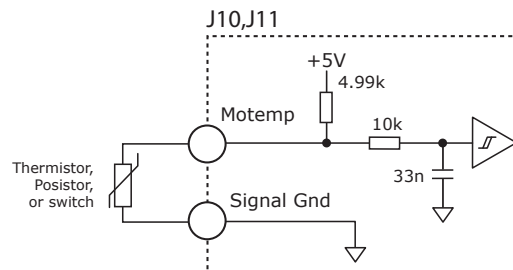

MULTI-MODE ENCODER PORT

The multi-mode port can operate as primary or secondary feedback from digital quad A/B/X or absolute encoders.

FEEDBACK FROM DIGITAL QUADRATURE ENCODER

When operating in position mode the multi-mode port can accept digital command signals from external encoders. These can be used to drive cam tables, or as master-encoder signals when operating in a master/slave configuration.

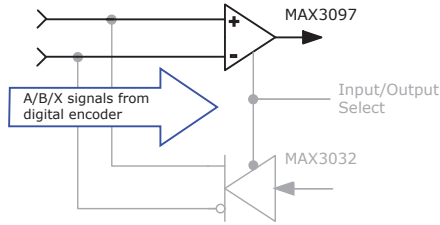

EMULATED QUAD A/B/X MULTI-PORT

Signal	Axis A Pin	Axis B Pin
Enc A	J12-36	J12-42
Enc /A	J12-21	J12-27
Enc B	J12-35	J12-41
Enc /B	J12-20	J12-26
Enc X	J12-34	J12-40
Enc /X	J12-19	J12-25
+5V	32,17	J12-38,23
Sgnd	J12-31,16	J12-37,22
Shld	J12-1	

FEEDBACK FROM ABSOLUTE ENCODERS

Digital absolute encoder feedback as motor or load encoder can come from absolute encoders, too. Analog sin/cos and index signals are not supported by the multi-port. The graphic to the right shows half-duplex format but both full and half-duplex operation are supported by the multi-port (see below)

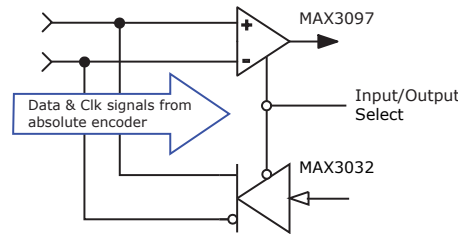

ABSOLUTE ENCODER, FULL-DUPLEX MODE

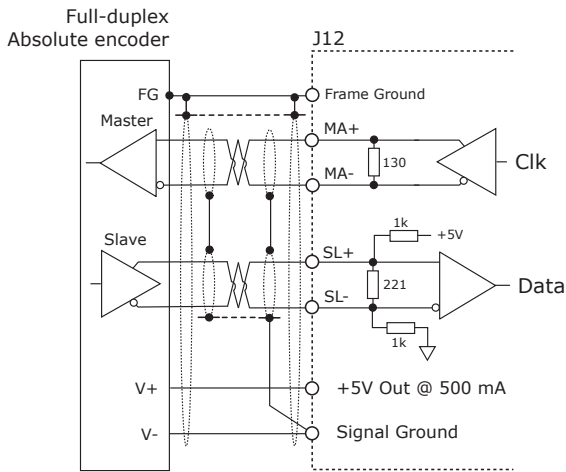

FULL-DUPLEX ENCODERS

- SSI
- BiSS
- EnDat

HALF-DUPLEX ENCODERS

- Absolute-A
- Sanyo Denki Absolute-A
- Tamagawa Absolute-A

FULL-DUPLEX SIGNALS

Signal	Axis A Pin	Axis B Pin
Clk, MA+	J12-34	J12-40
/Clk, MA-	J12-19	J12-25
Dat, SL+	J12-33	J12-39
/Dat, SL-	J12-18	J12-24
+5V	J12-32,17	J12-38,23
Sgnd	J12-31,16	J12-37,22
Shld	J12-1	

ABSOLUTE ENCODER, HALF-DUPLEX MODE

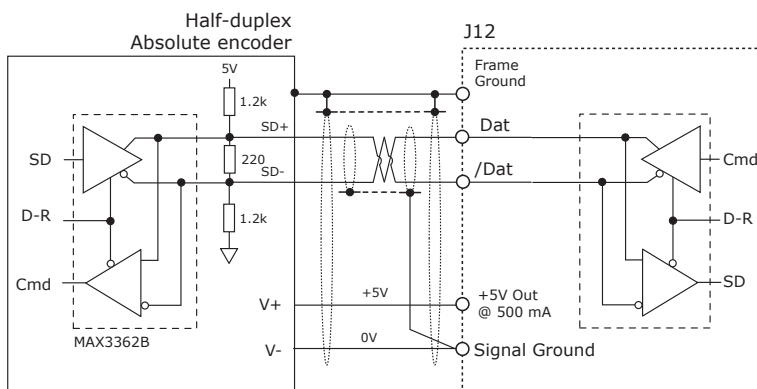

HALF-DUPLEX SIGNALS

Signal	Axis A Pin	Axis B Pin
Dat	J12-33	J12-39
/Dat	J12-18	J12-24
+5V	J12-32,17	J12-38,23
Sgnd	J12-31,16	J12-37,22
Shld	J12-1	

MULTI-MODE ENCODER PORT: COMMAND INPUTS

AS A MASTER OR CAMMING ENCODER INPUT FROM A DIGITAL QUADRATURE ENCODER

When operating in position mode the multi-mode port can accept digital command signals from external encoders. These can be used to drive cam tables, or as master-encoder signals when operating in a master/slave configuration.

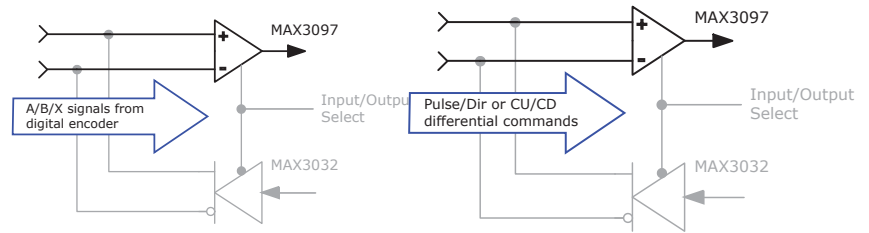

COMMAND INPUTS MULTI-PORT

Signal			Axis A Pin	Axis B Pin
Enc A	Pulse	CW	J12-36	J12-42
Enc /A	/Pulse	/CW	J12-21	J12-27
Enc B	Dir	CCW	J12-35	J12-41
Enc /B	/Dir	/CCW	J12-20	J12-26
Enc X			J12-34	J12-40
Enc /X			J12-19	J12-25
+5V			32,17	J12-38,23
Sgnd			J12-31,16	J12-37,22
Frame Gnd			J12-1	

AS DIGITAL COMMAND INPUTS IN PULSE/DIRECTION, PULSE-UP/PULSE-DOWN, OR DIGITAL QUADRATURE ENCODER FORMAT

The multi-mode port can also be used when digital command signals are in a differential format. These are the signals that typically go to single-ended inputs. But, at higher frequencies these are likely to be differential signals in which case the multi-mode port can be used.

MULTI-MODE ENCODER PORT: FEEDBACK OUTPUTS

AS BUFFERED OUTPUTS FROM A DIGITAL QUADRATURE PRIMARY ENCODER

When using a digital quadrature feedback encoder, the A/B/X signals drive the multi-mode port output buffers directly. This is useful in systems that use external controllers that also need the motor feedback encoder signals because these now come from J12, the Control connector. In addition to eliminating "Y" cabling where the motor feedback cable has to split to connect to both controller and motor, the buffered outputs reduce loading on the feedback cable that could occur if the motor encoder had to drive two differential inputs in parallel, each with its own 121 ohm terminating resistor.

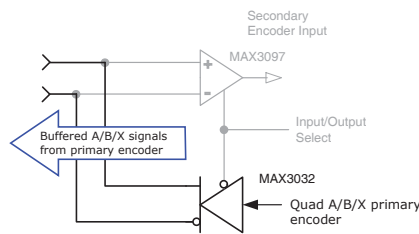

BUFFERED OUTPUTS MULTI-PORT

Signal	Axis A Pin	Axis B Pin
Enc A	J12-36	J12-42
Enc /A	J12-21	J12-27
Enc B	J12-35	J12-41
Enc /B	J12-20	J12-26
Enc X	J12-34	J12-40
Enc /X	J12-19	J12-25
+5V	32,17	J12-38,23
Sgnd	J12-31,16	J12-37,22
F.G.	J12-1	

AS EMULATED QUAD A/B/X ENCODER OUTPUTS FROM AN ANALOG SIN/COS FEEDBACK ENCODER

Analog sin/cos signals are interpolated in the drive with programmable resolution. The incremental position data is then converted back into digital quadrature format which drives the multi-mode port output buffers. Some analog encoders also produce a digital index pulse which is connected directly to the port's output buffer. The result is digital quadrature A/B/X signals that can be used as feedback to an external control system.

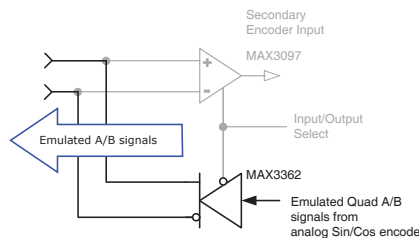

Notes for XP2-230-20-R model:

* Buffered outputs from digital encoders on J10 & J11 are not supported.

** Emulated quad A/B outputs are only supported for resolver feedback

CME2 & AXIS A I/O CONNECTIONS

CME2 SCREEN FOR INPUTS [IN1~IN10]

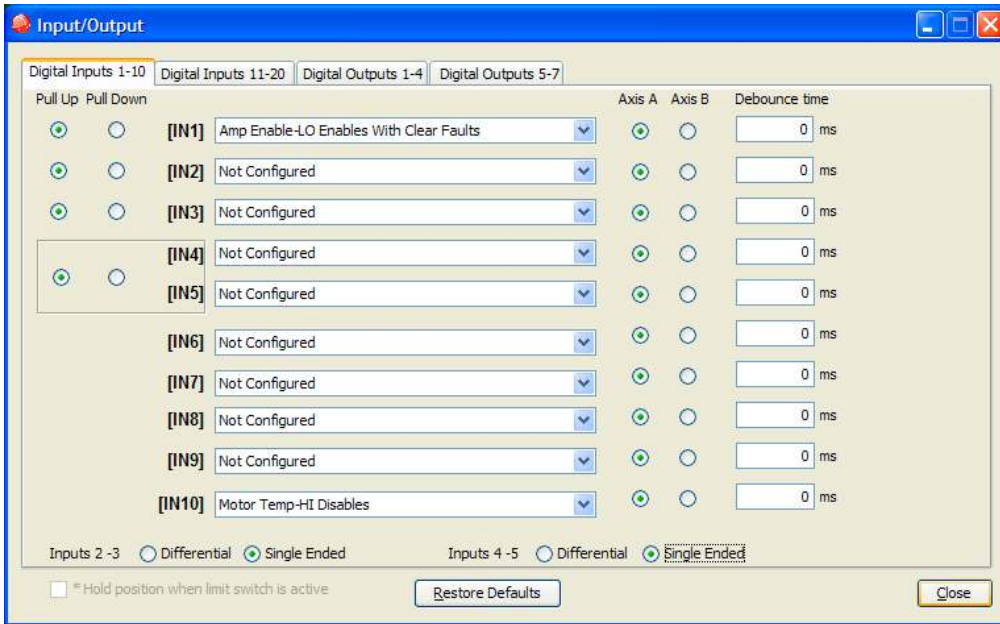

INPUT DATA

Input	Pin	R1	R2	C1
IN1	J12-7	10k	10k	100p
IN2	J12-8	10k	1k	100p
IN3	J12-9			
IN4	J12-10			
IN5	J12-11			
IN6	J10-2	Opto		
IN7	J10-3			
IN8	J10-4			
IN9	J10-5			
ICOM1	J10-6			
IN10	J11-7	4.99k	10k	33n
IN21	J11-24	10k	10k	100p

+30Vmax
+24V typical
+24V
Vmax
+12V

[IN1]

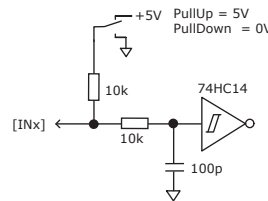

[IN2~5]

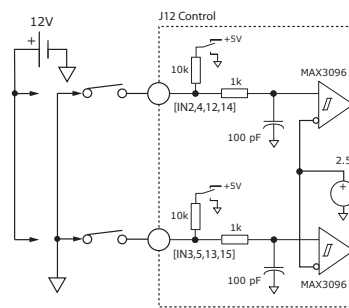

[IN6~9]

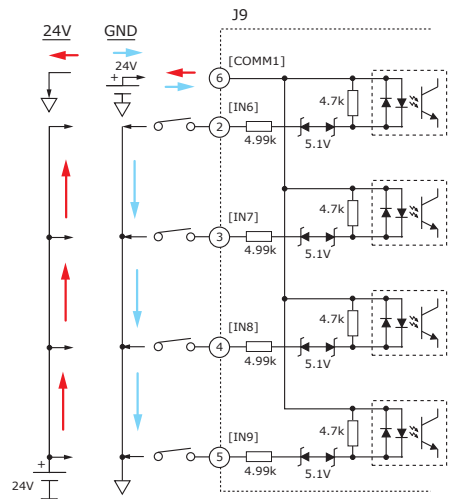

HI/LO DEFINITIONS: INPUTS

Input	State	Condition
IN1,10,21	HI	Vin >= 2.5 Vdc
	LO	Vin <= 1.3 Vdc
IN2~5	HI	Vin > 2.5 Vdc
	LO	Vin < 2.5 Vdc
IN6~9	HI	Input diode ON
	LO	Input diode OFF

IN6~9 are optically isolated and work from positive or negative input voltages. When voltage is applied to an input and current flows through the input diode of the opto-coupler the diode condition is ON. When no voltage is applied to an input and no current flows through the input diode it is OFF.

INPUTS WITH PROGRAMMABLE PULL UP/DOWN

Input	Pin	PU/PD
IN1	J12-7	1
IN2	J12-8	2
IN3	J12-9	3
IN4	J12-10	4
IN5	J12-11	

[IN10]

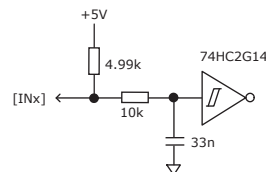

[IN21]

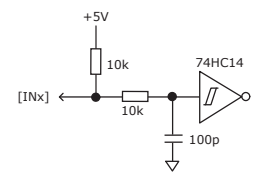

CME2 & AXIS B I/O CONNECTIONS

CME2 SCREEN FOR INPUTS [IN11~IN20]

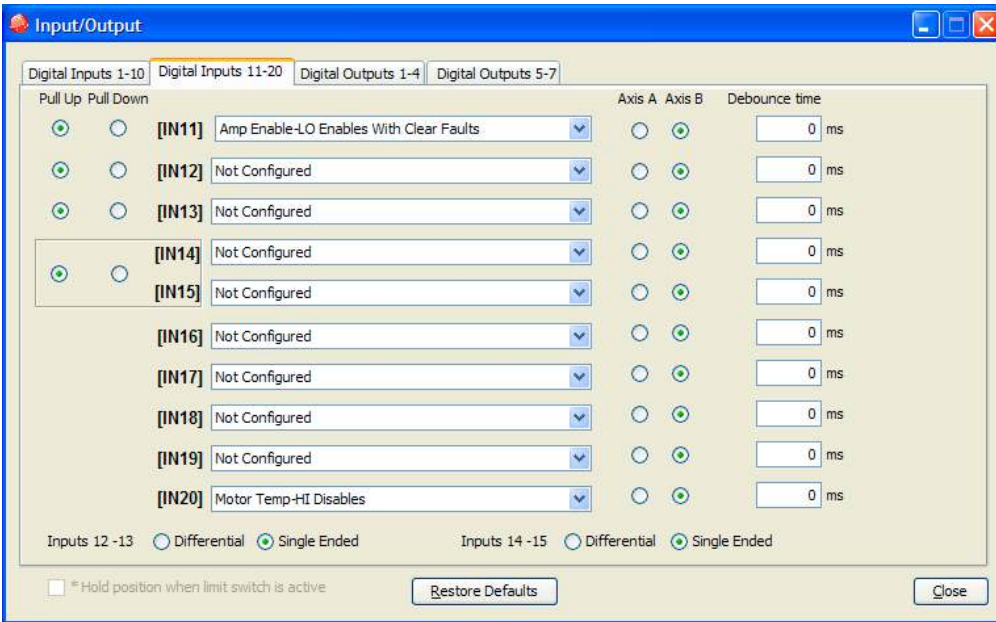

INPUT DATA

Input	Pin	R1	R2	C1
IN11	J12-12	10k	10k	100p
IN12	J12-13	10k	1k	100p
IN13	J12-14			
IN14	J12-15			
IN15	J12-30			
IN16	J9-7	Opto		
IN17	J9-8			
IN18	J9-9			
IN19	J9-18			
ICOM2	J9-17			
IN20	J11-7	4.99k	10k	33n
IN22	J11-24	10k	10k	100p

+30Vmax
+24V typical
+24V
Vmax
+12V

[IN11]

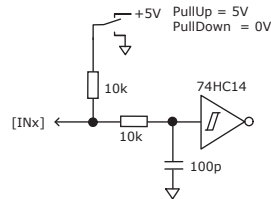

[IN12~15]

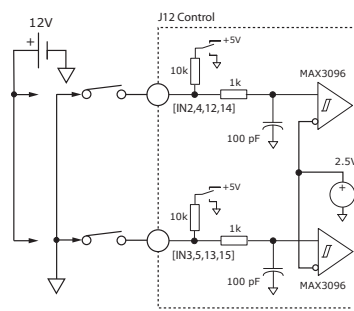

[IN16~19]

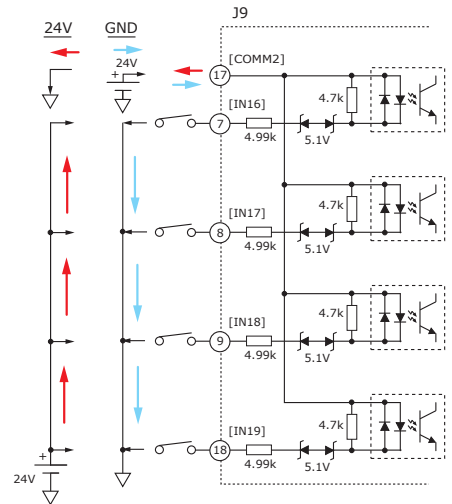

HI/LO DEFINITIONS: INPUTS

Input	State	Condition
IN11,20,22	HI	Vin >= 2.5 Vdc
	LO	Vin <= 1.3 Vdc
IN12~15	HI	Vin > 2.5 Vdc
	LO	Vin < 2.5 Vdc
IN16~19	HI	Input diode ON
	LO	Input diode OFF

IN16~19 are optically isolated and work from positive or negative input voltages. When voltage is applied to an input and current flows through the input diode of the opto-coupler the diode condition is ON. When no voltage is applied to an input and no current flows through the input diode it is OFF.

INPUTS WITH PROGRAMMABLE PULL UP/DOWN

Input	Pin	PU/PD
IN11	J12-12	5
IN12	J12-13	6
IN13	J12-14	7
IN14	J12-15	8
IN15	J12v-30	

[IN20]

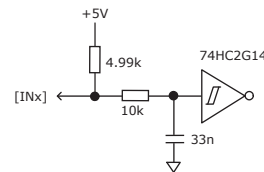

[IN22]

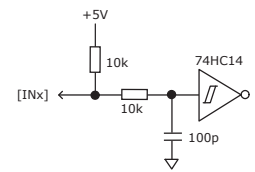

CME2 & OUTPUTS 1~4 CONNECTIONS

OUTPUT CONNECTIONS

CME2 SCREEN FOR OUTPUTS [OUT1~4]

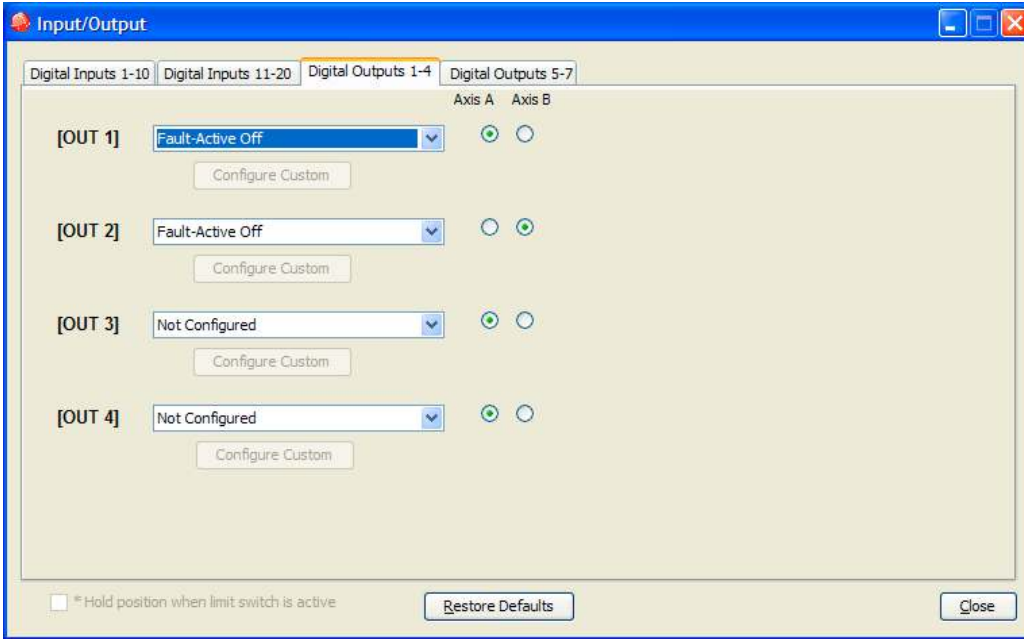

OUTPUT DATA

[OUT1~4] SIGNALS

Signal	Pins	Signal	Pins
[OUT1+]	J9-19	[OUT1-]	J9-10
[OUT2+]	J9-20	[OUT2-]	J9-11
[OUT3+]	J9-21	[OUT3-]	J9-12
[OUT4+]	J9-22	[OUT4-]	J9-13

HI/LO DEFINITIONS: OUTPUTS

Input	State	Condition
OUT1~4	HI	Output transistor is ON, current flows
	LO	Output transistor is OFF, no current flow

[OUT1~4]

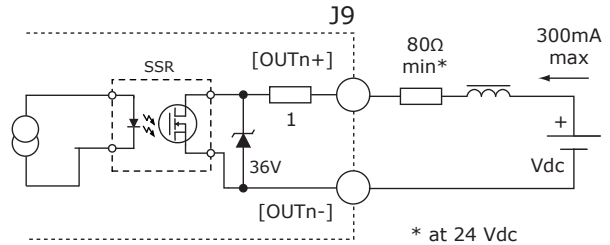

CME2 & OUTPUTS 5~7 CONNECTIONS

CME2 SCREEN FOR OUTPUTS [OUT5~7]

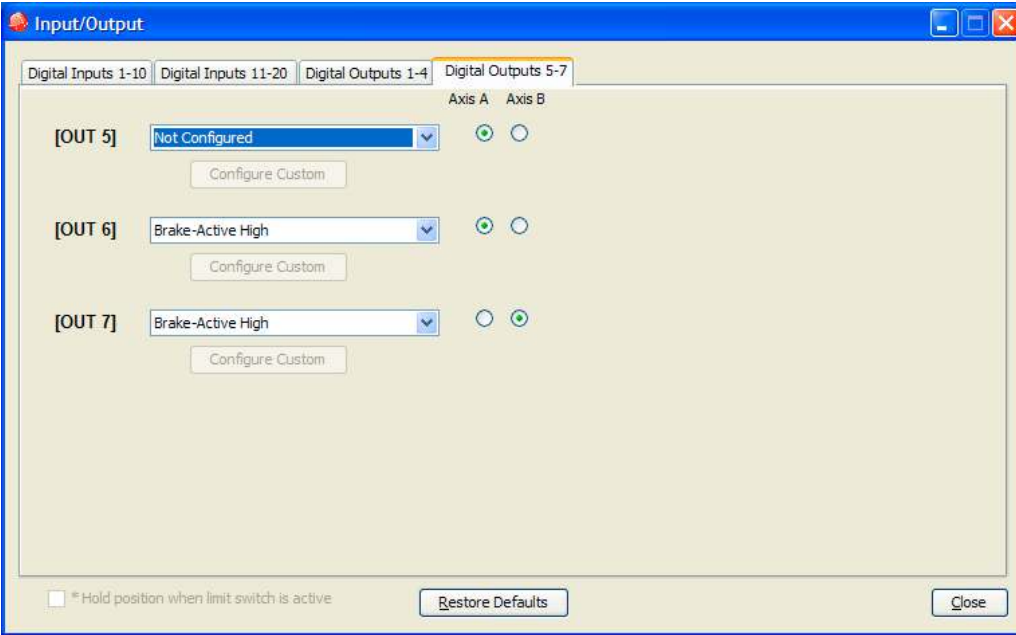

OUTPUT DATA
[OUT5~7] SIGNALS

Signal	Pins
[OUT5+]	J9-23
[OUT5-]	J9-14
[OUT6]	J5-3
[OUT7]	J5-2

+30Vmax
+24V typical
+24V

HI/LO DEFINITIONS: OUTPUTS

Input	State	Condition
OUT5	HI	Output transistor is ON, current flows
	LO	Output transistor is OFF, no current flows
BRK-A,B OUT6,7	HI	Output transistor is OFF Brake is un-powered and locks motor shaft Motor cannot move Brake state is Active
	LO	Output transistor is ON Brake is powered, releasing motor shaft Motor is free to move Brake state is NOT-Active

CME2 Default Setting for Brake Outputs [OUT6,7] is "Brake - Active HI"

Active = Brake is holding motor shaft (i.e. the Brake is Active)
 Motor cannot move
 No current flows in coil of brake
 CME2 I/O Line States shows Output 6 or 7 as HI
 BRK Output voltage is HI (24V), MOSFET is OFF
 Servo drive output current is zero
 Servo drive is disabled, PWM outputs are off

Inactive = Brake is not holding motor shaft (i.e. the Brake is Inactive)
 Motor can move
 Current flows in coil of brake
 CME2 I/O Line States shows Output 6 or 7 as LO
 BRK output voltage is LO (~0V), MOSFET is ON
 Servo drive is enabled, PWM outputs are on
 Servo drive output current is flowing

[OUT5]

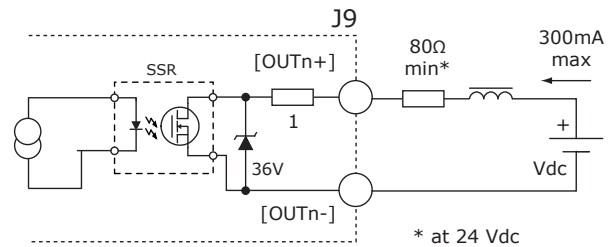

[BRK-A,B]
[OUT6~7]

Signal	Pins
Brake A	J5-3
Brake B	J5-2

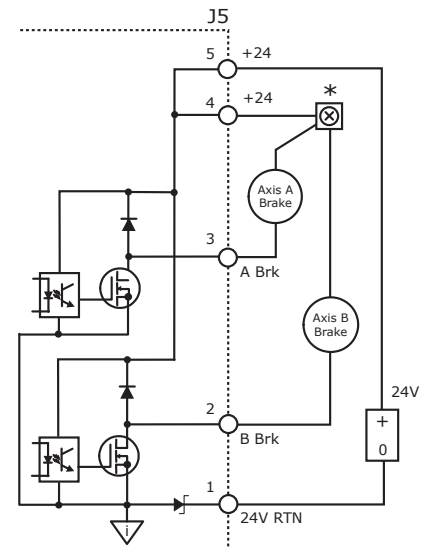

MOTOR CONNECTIONS FOR DIGITAL INCREMENTAL ENCODERS: XP2-230-20

For XP2-230-20-R, digital encoder feedback is not supported on J10 & J11. Use the Multi-Port on J12 for this type of feedback.

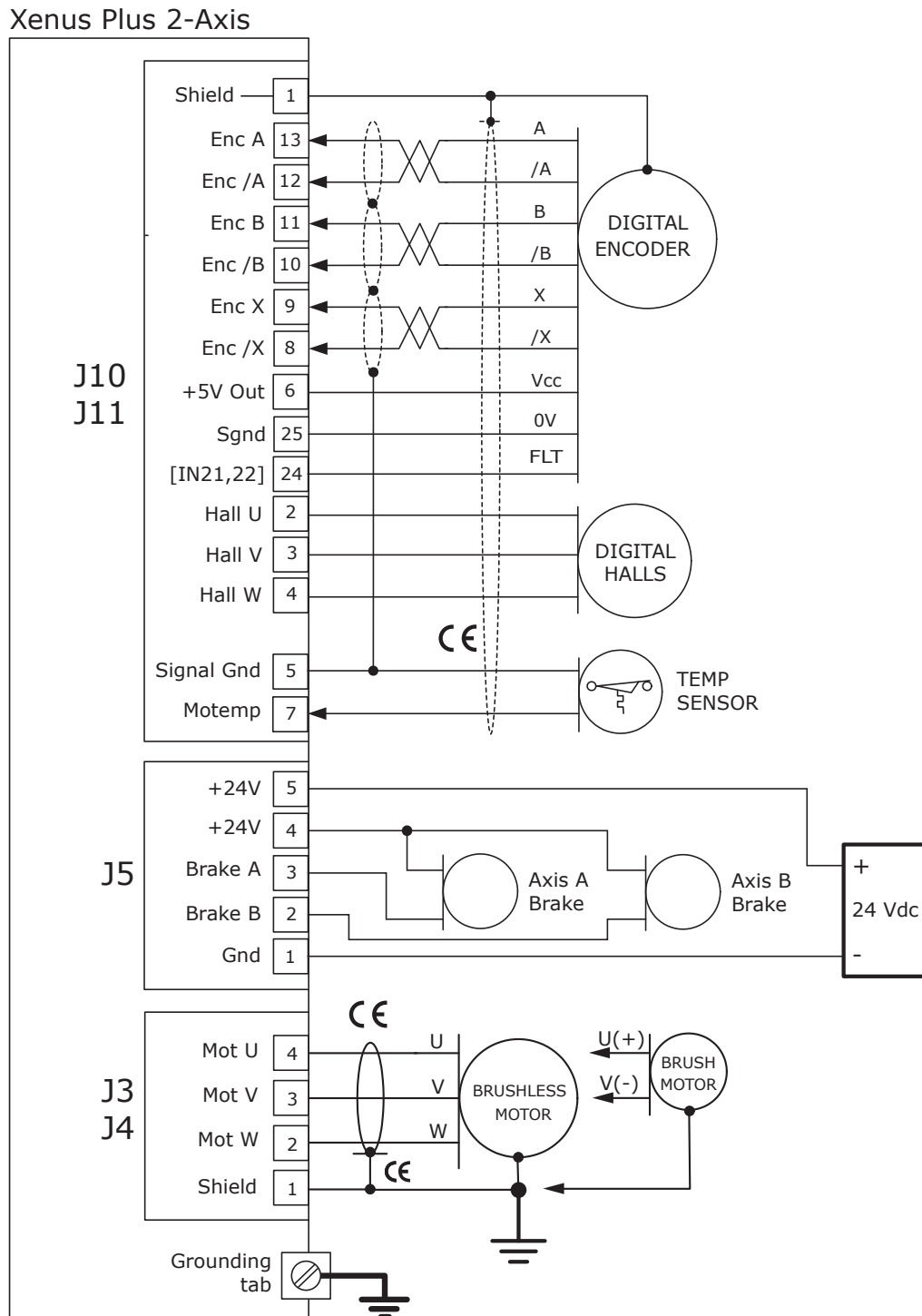

NOTES:

- 1) +5V Out on J10 & J11 are independent power supplies and each is rated for 500 mA
- 2) CE symbols indicate connections required for CE compliance.

For XP2-230-20-R, Sin/Cos/Index encoder feedback is not supported.

Xenus Plus 2-Axis

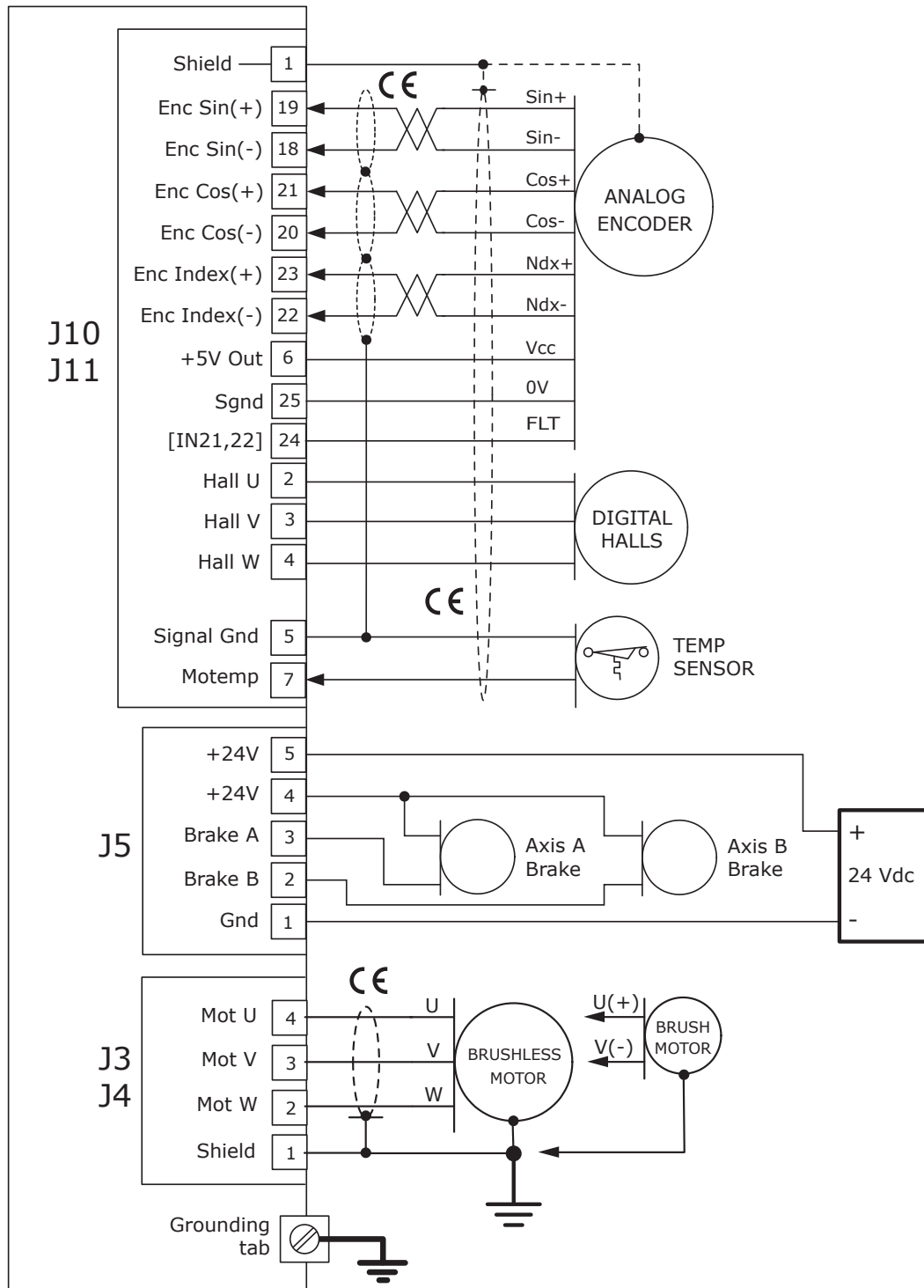

NOTES:

- 1) +5V Out on J10 & J11 are independent power supplies and each is rated for 500 mA
- 2) CE symbols indicate connections required for CE compliance.

MOTOR CONNECTIONS FOR RESOLVERS: XP2-230-20-R

Digital incremental and absolute encoders may be connected to the Multi-Port on J12.

Xenus Plus 2-Axis

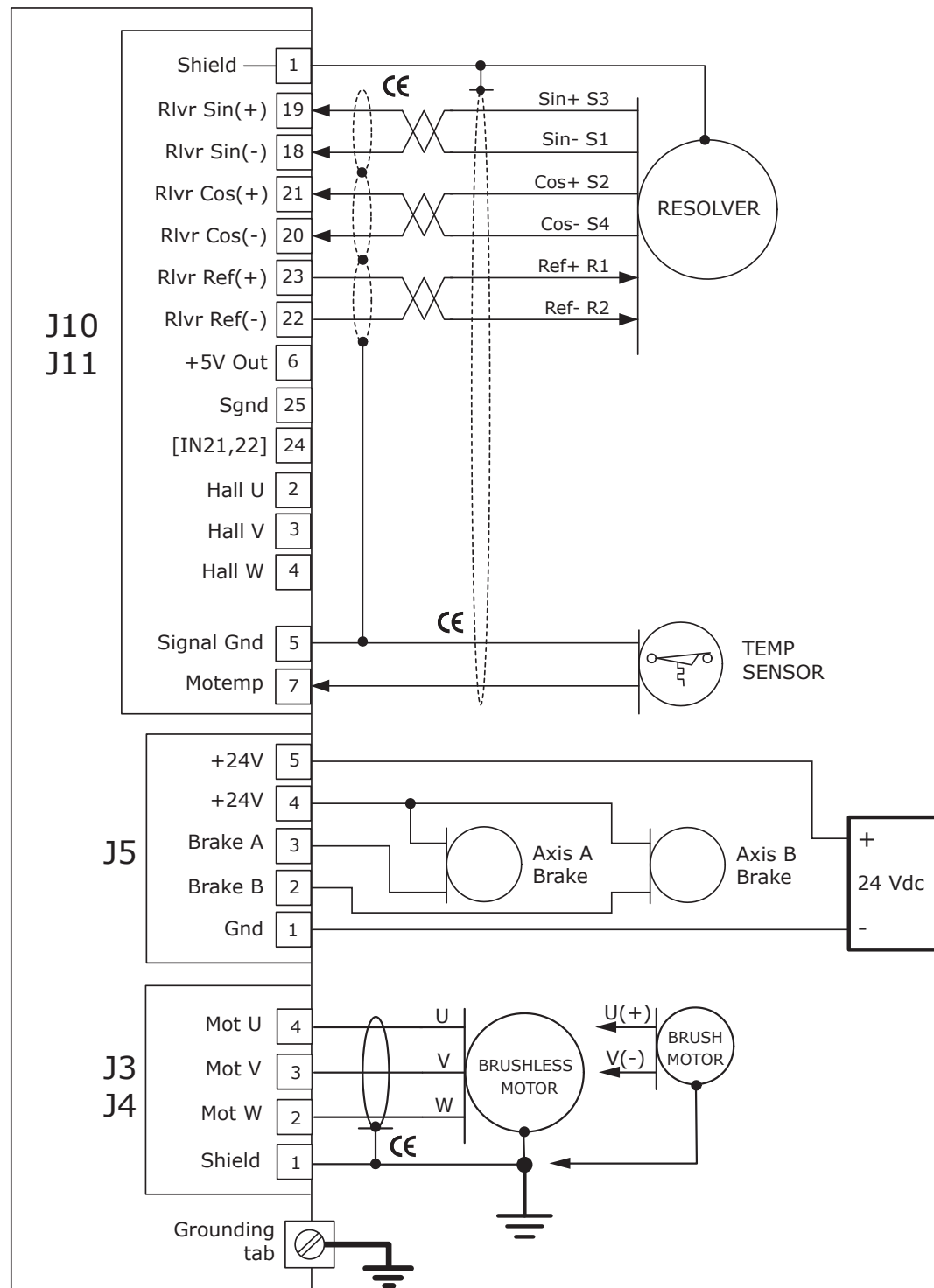

NOTES:

- 1) +5V Out on J10 & J11 are independent power supplies and each is rated for 500 mA
- 2) CE symbols indicate connections required for CE compliance.

CONNECTIONS FOR XP2-230-20

WARNING: Hazardous voltages exist on connections to J1, J2, J3 & J4 when power is applied, and for up to 4 minutes after power is removed.

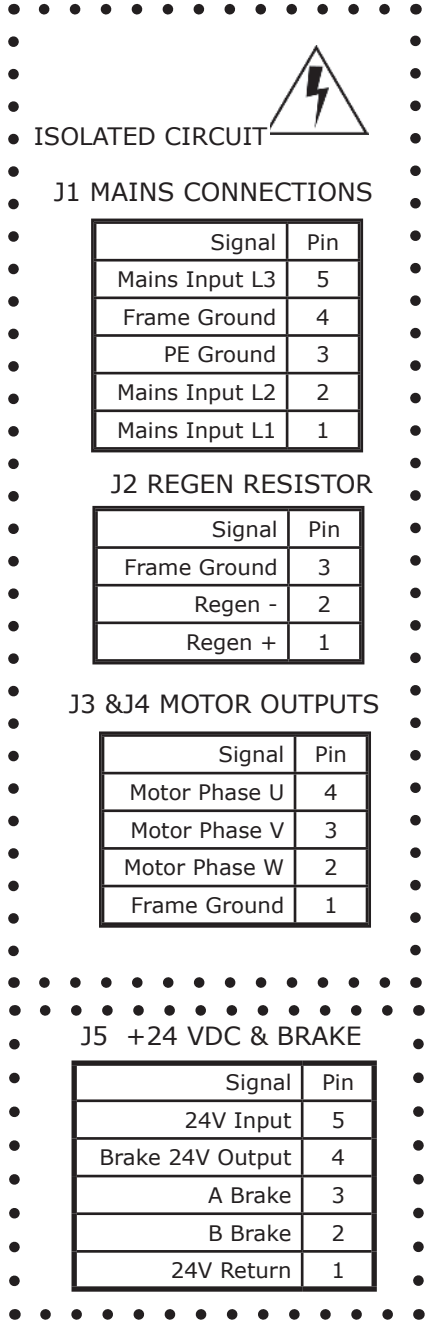

J5 STO

PIN	SIGNAL	PIN	SIGNAL
1	Frame Gnd	6	STO-1(+)
2	STO-1(+)	7	STO-1(-)
3	STO-1(-)	8	STO-24V
4	STO-2(+)	9	STO-GND
5	STO-1(-)		

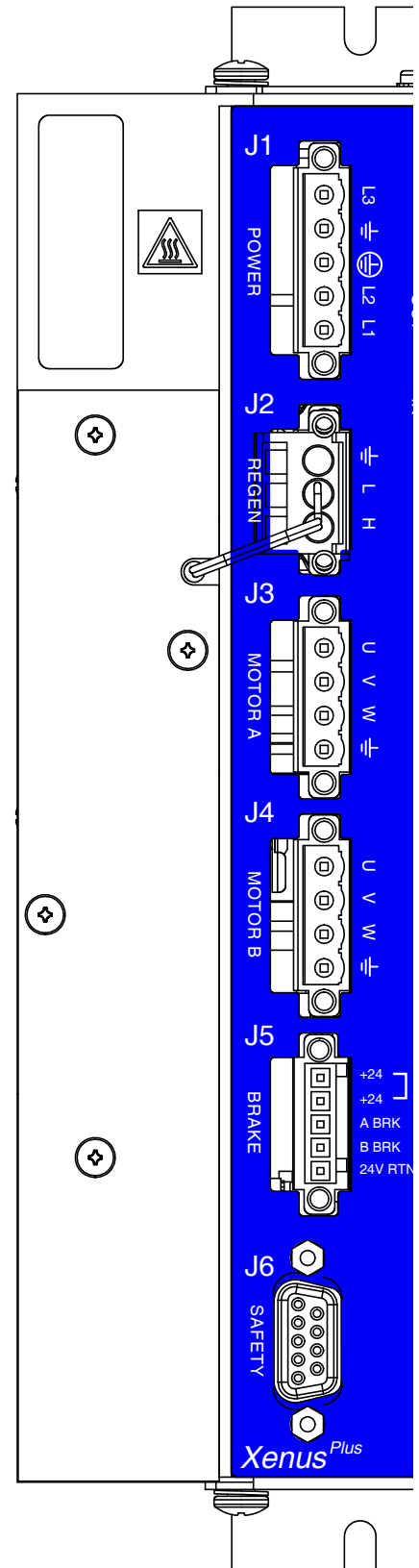

SIGNAL CONNECTIONS FOR XP2-230-20

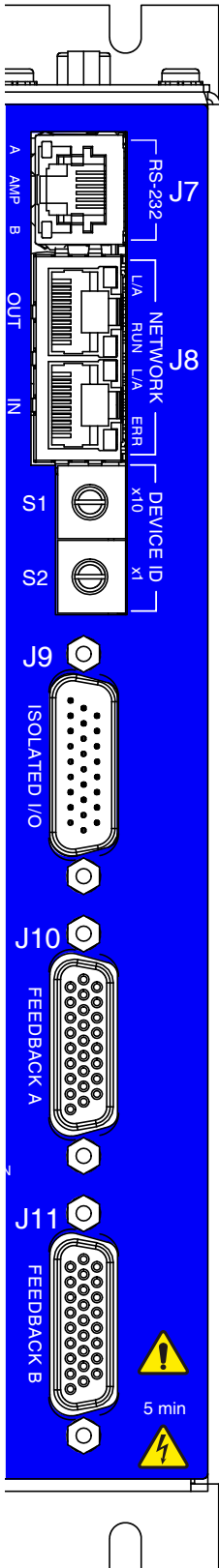

J12 CONTROL (ON END PANEL)

PIN	SIGNAL	PIN	SIGNAL	PIN	SIGNAL
1	Frame Gnd	16	Signal Gnd	31	Signal Gnd
2	Ref1(-)	17	5V Out3	32	5V Out3
3	Ref1(+)	18	A-MultiEnc /S	33	A-MultiEnc S
4	Ref2(-)	19	A-MultiEnc /X	34	A-MultiEnc X
5	Ref2(+)	20	A-MultiEnc /B	35	A-MultiEnc B
6	Signal Gnd	21	A-MultiEnc /A	36	A-MultiEnc A
7	[IN1] GP	22	Signal Gnd	37	Signal Gnd
8	[IN2] GP	23	5V Out4	38	5V Out4
9	[IN3] GP	24	B-MultiEnc /S	39	B-MultiEnc S
10	[IN4] GP	25	B-MultiEnc /X	40	B-MultiEnc X
11	[IN5] HS	26	B-MultiEnc /B	41	B-MultiEnc B
12	[IN11] HS	27	B-MultiEnc /A	42	B-MultiEnc A
13	[IN12] HS	28	n.c.	43	n.c.
14	[IN13] HS	29	n.c.	44	Signal Gnd
15	[IN14] HS	30	[IN15]		

J9 ISOLATED I/O

PIN	SIGNAL	PIN	SIGNAL	PIN	SIGNAL
9	[IN18] GPI	18	[IN19] GPI	26	n.c.
8	[IN17] GPI	17	[IN16~19] COMM	25	n.c.
7	[IN16] GPI	16	n.c.	24	n.c.
6	[IN6~9] COMM	15	n.c.	23	[OUT5+]
5	[IN9] GPI	14	[OUT5-]	22	[OUT4+]
4	[IN8] GPI	13	[OUT4-]	21	[OUT3+]
3	[IN7] GPI	12	[OUT3-]	20	[OUT2+]
2	[IN6] GPI	11	[OUT2-]	19	[OUT1+]
1	Frame Ground	10	[OUT1-]		

J10, J11 FEEDBACK

PIN	SIGNAL	PIN	SIGNAL	PIN	SIGNAL
1	Frame Gnd	10	Enc /B	19	Sin1(+)
2	Hall U	11	Enc B	20	Cos1(-)
3	Hall V	12	Enc /A	21	Cos1(+)
4	Hall W	13	Enc A	22	Indx(-)
5	Signal Gnd	14	Enc /S	23	Indx(+)
6	+5V Out1(2)	15	Enc S	24	EncFault
7	Motemp IN10(20)	16	Signal Gnd	25	Signal Gnd
8	Enc /X	17	+5V Out1(2)	26	Signal Gnd
9	Enc X	18	Sin1(-)		

Note: Signals unique to axis A or axis B are shown as "Xxx A(B)"

All other signals are common to both axes A & B

CONNECTIONS FOR XP2-230-20-R

WARNING: Hazardous voltages exist on connections to J1, J2, J3 & J4 when power is applied, and for up to 5 minutes after power is removed.



ISOLATED CIRCUIT

J1 MAINS CONNECTIONS

Signal	Pin
Mains Input L3	5
Frame Ground	4
PE Ground	3
Mains Input L2	2
Mains Input L1	1

J2 REGEN RESISTOR

Signal	Pin
Frame Ground	3
Regen -	2
Regen +	1

J3 & J4 MOTOR OUTPUTS

Signal	Pin
Motor Phase U	4
Motor Phase V	3
Motor Phase W	2
Frame Ground	1

J5 +24 VDC & BRAKE

Signal	Pin
24V Input	5
Brake 24V Output	4
A Brake	3
B Brake	2
24V Return	1

J5 STO

PIN	SIGNAL	PIN	SIGNAL
1	Frame Gnd	6	STO-1(+)
2	STO-1(+)	7	STO-1(-)
3	STO-1(-)	8	STO-24V
4	STO-2(+)	9	STO-GND
5	STO-1(-)		

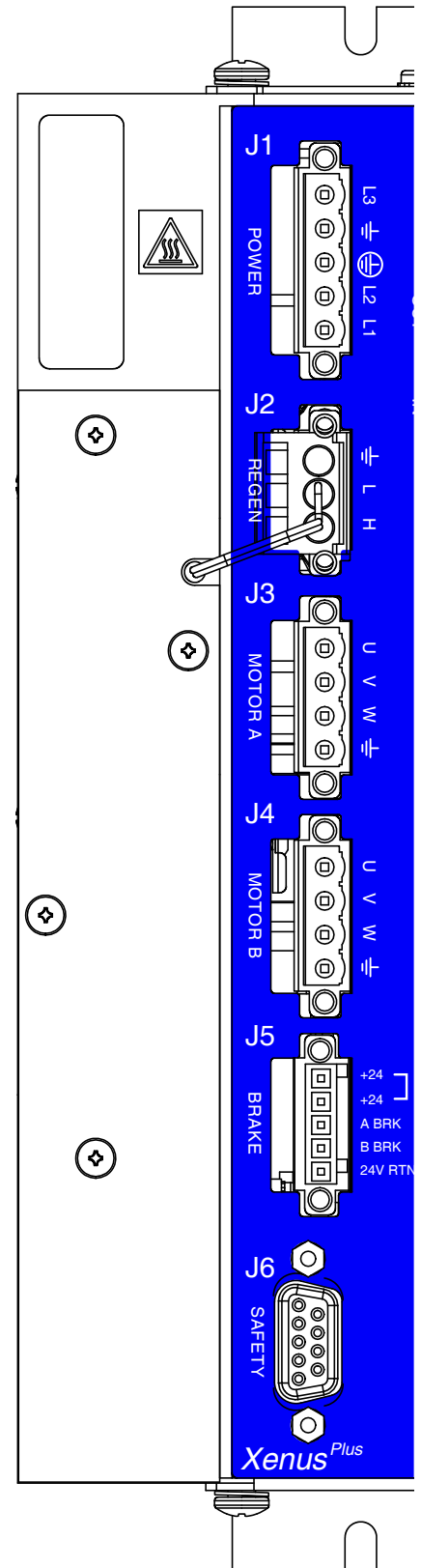

SIGNAL CONNECTIONS FOR XP2-230-R

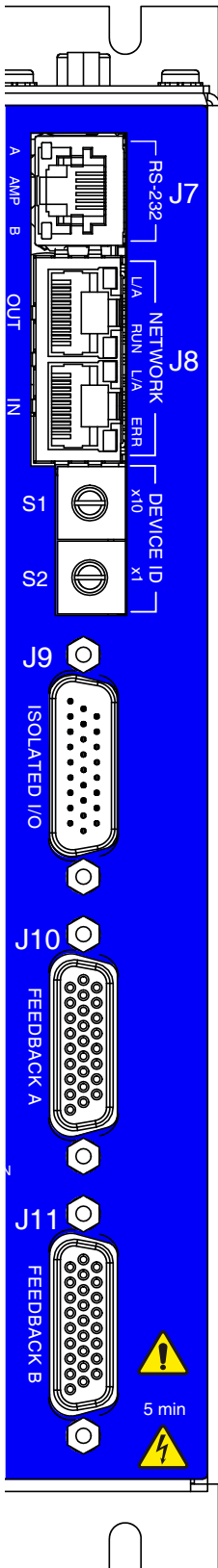

J12 CONTROL (ON END PANEL)

PIN	SIGNAL	PIN	SIGNAL	PIN	SIGNAL
1	Frame Gnd	16	Signal Gnd	31	Signal Gnd
2	Ref1(-)	17	5V Out3	32	5V Out3
3	Ref1(+)	18	A-MultiEnc /S	33	A-MultiEnc S
4	Ref2(-)	19	A-MultiEnc /X	34	A-MultiEnc X
5	Ref2(+)	20	A-MultiEnc /B	35	A-MultiEnc B
6	Signal Gnd	21	A-MultiEnc /A	36	A-MultiEnc A
7	[IN1] GP	22	Signal Gnd	37	Signal Gnd
8	[IN2] GP	23	5V Out4	38	5V Out4
9	[IN3] GP	24	B-MultiEnc /S	39	B-MultiEnc S
10	[IN4] GP	25	B-MultiEnc /X	40	B-MultiEnc X
11	[IN5] HS	26	B-MultiEnc /B	41	B-MultiEnc B
12	[IN11] HS	27	B-MultiEnc /A	42	B-MultiEnc A
13	[IN12] HS	28	n.c.	43	n.c.
14	[IN13] HS	29	n.c.	44	Signal Gnd
15	[IN14] HS	30	[IN15]		

J9 ISOLATED I/O

PIN	SIGNAL	PIN	SIGNAL	PIN	SIGNAL
9	[IN18] GPI	18	[IN19] GPI	26	n.c.
8	[IN17] GPI	17	[IN16~19] COMM	25	n.c.
7	[IN16] GPI	16	n.c.	24	n.c.
6	[IN6~9] COMM	15	n.c.	23	[OUT5+]
5	[IN9] GPI	14	[OUT5-]	22	[OUT4+]
4	[IN8] GPI	13	[OUT4-]	21	[OUT3+]
3	[IN7] GPI	12	[OUT3-]	20	[OUT2+]
2	[IN6] GPI	11	[OUT2-]	19	[OUT1+]
1	Frame Ground	10	[OUT1-]		

J10, J11 FEEDBACK

N.C. = No Connection

PIN	SIGNAL	PIN	SIGNAL	PIN	SIGNAL
1	Frame Gnd	10	N.C.	19	Sin1(+) S3
2	Hall U	11	N.C.	20	Cos1(-) S4
3	Hall V	12	N.C.	21	Cos1(+) S2
4	Hall W	13	N.C.	22	Ref(-) R2
5	Signal Gnd	14	N.C.	23	Ref(+) R1
6	+5V Out1(2)	15	N.C.	24	EncFault
7	Motemp IN10(20)	16	Signal Gnd	25	Signal Gnd
8	N.C.	17	+5V Out1(2)	26	Signal Gnd
9	N.C.	18	Sin1(-) S1		

Note: Signals unique to axis A or axis B are shown as "Xxx A(B)"

All other signals are common to both axes A & B

WIRING

AC POWER, REGEN, AND MOTOR OUTPUTS: J1~J4

Wago MCS-MIDI Classic: 231-305/107-000 (J1) 231-303/107-000 (J2), 231-304/107-000 (J3, J4), female connector; with screw flange; 3-pole; pin spacing 5.08 mm / 0.2 in

Conductor capacity

Bare stranded: AWG 28~14 [0.08~2.5 mm²]

Insulated ferrule: AWG 24~16 [0.25~1.5 mm²]

Stripping length: 8~9 mm

Operating Tool: Wago MCS-MIDI Classic: 231-159



FERRULE PART NUMBERS: SINGLE WIRE INSULATED

AWG	mm ²	Color	Mfgr	PNUM	A	B	C	D	E	SL
14	2.5	Blue	Wago	216-206	15.0 (0.59)	8.0 (0.31)	2.05 (.08)	4.2 (0.17)	4.8 (0.19)	10 (0.39)
16	1.5	Black	Wago	216-204	14.0 (0.59)	8.0 (0.31)	1.7 (.07)	3.5 (0.14)	4.0 (0.16)	10 (0.39)
18	1.0	Red	Wago	216-223	12.0 (.47)	6.0 (.24)	1.4 (.055)	3.0 (.12)	3.5 (.14)	8 (.31)
20	0.75	Gray	Wago	216-222	12.0 (.47)	6.0 (.24)	1.2 (.047)	2.8 (.11)	3.3 (.13)	8 (.31)
22	0.5	White	Wago	216-221	12.0 (.47)	6.0 (.24)	1.0 (.039)	2.6 (.10)	3.1 (.12)	7.5 (.30)

NOTES

PNUM = Part Number

SL = Stripping length

Dimensions: mm (in)

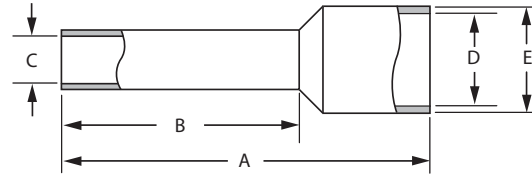

24V & BRAKE: J5

Wago MCS-MINI: 734-105/107-000, female connector; with screw flange, 5-pole; pin spacing 3.5 mm / 0.138 in

Conductor capacity

Bare stranded: AWG 28~16 [0.08~1.5 mm²]

Insulated ferrule: AWG 24~16 [0.25~1.5 mm²]

Stripping length: 0.24~0.28 in [6~7 mm]

Operating tool: Wago MCS-MINI: 734-231



FERRULE PART NUMBERS: SINGLE WIRE INSULATED

AWG	mm ²	Color	Mfgr	PNUM	A	B	C	D	E	SL
18	1.0	Red	Wago	216-223	12.0 (.47)	6.0 (.24)	1.4 (.06)	3.0 (.12)	3.5 (.14)	8 (.31)
20	0.75	Gray	Wago	216-222	12.0 (.47)	6.0 (.24)	1.2 (.05)	2.8 (.11)	3.3 (.13)	8 (.31)
22	0.5	White	Wago	216-221	12.0 (.47)	6.0 (.24)	1.0 (.04)	2.6 (.10)	3.1 (.12)	7.5 (.30)

FERRULE PART NUMBERS: DOUBLE WIRE INSULATED

AWG	mm ²	Color	Mfgr	PNUM	A	B	C	D	E	SL
2 x 18	2 x 1.0	Red	Altech	2776.0	15.4 (.61)	8.2 [.32]	2.4 (.09)	3.2 (.13)	5.8 (.23)	11.0 (.43)
2 x 18	2 x 1.0	Gray	Altech	2775.0	14.6 (.57)	8.2 (.32)	2.0 (.08)	3.0 (.12)	5.5 (.22)	11.0 (.43)
2 x 20	2 x 0.75	White	Altech	2794.0	14.6 (.57)	8.2 (.32)	1.7 (.07)	3.0 (.12)	5.0 (.20)	11.0 (.43)
2 x 20	2 x 0.75	Gray	TE	966144-2	15.0 (.59)	8.0 (.31)	1.70 (.07)	2.8 (.11)	5.0 (.20)	10 (.39)
2 x 22	2 x 0.50	White	TE	966144-1	15.0 (.59)	8.0 (.31)	1.40 (.06)	2.5 (.10)	4.7 (.19)	10 (.39)

SINGLE WIRE

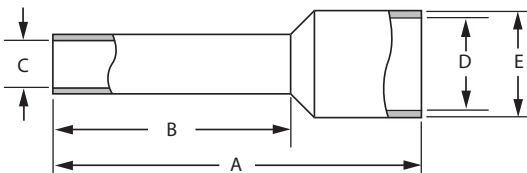

DOUBLE WIRE

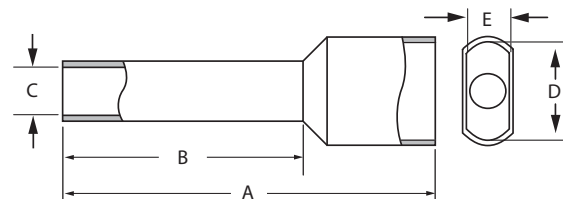

POWER & GROUNDING

DRIVE POWER SOURCES

An external +24 Vdc power supply is required, and powers an internal DC/DC converter that supplies all the control voltages for drive operation. Use of an external supply enables CANopen communication with the drive when the mains power has been removed. Power distribution in XP2 is divided into three sections: +24 Vdc, signal, and high-voltage. Each is isolated from the other and all are isolated from the chassis.

EXTERNAL +24 VDC

The primary side of the DC/DC converter operates directly from the external +24 Vdc supply and is isolated from other drive power sections. The Brake outputs operate in this section and are referenced to the +24 Vdc return (0V). They sink current from an external load connected to the external +24 Vdc power source.

INTERNAL SIGNAL POWER

The signal power section supplies power for the control circuits as well as logic inputs and outputs. Motor feedback signals such as Halls, encoder, and temperature sensor operate from this power source. All signal circuits are referenced to signal ground. This ground should connect to the control system circuit ground or common so that drive and controller inputs and output voltage levels work properly with each other.

POWER SECTIONS

The graphic below shows the different power sections of the Xenus Plus drive and the isolation barriers between them. Only one motor is shown but all motor PWM drivers are in the mains-connected section.

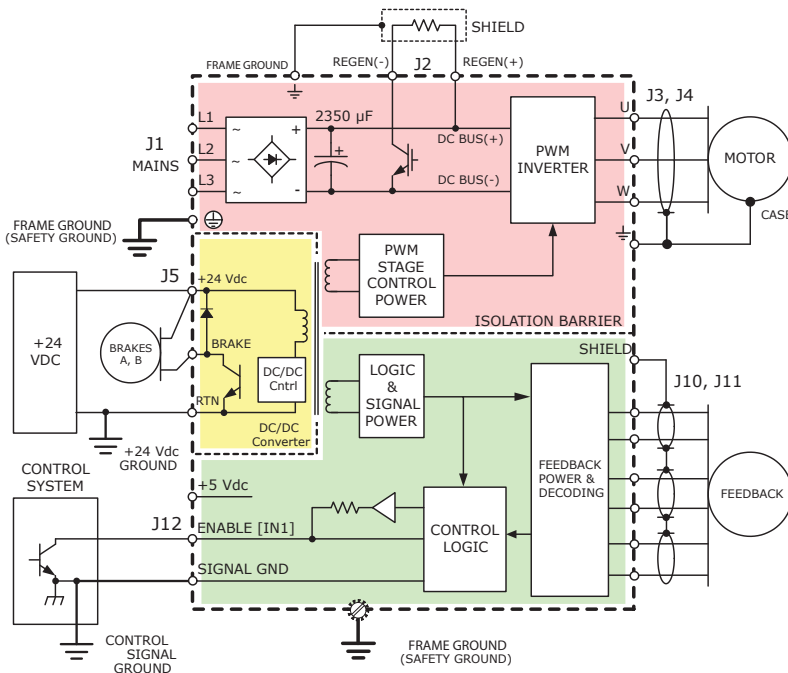

MAINS POWER

Mains power drives the high-voltage section. It is rectified and capacitor-filtered to produce +HV which the PWM stages convert into voltages that drive either three phase brushless or DC brush motors. An internal solid-state switch together with an external power resistor provides dissipation during regeneration when the mechanical energy of the motors is converted back into electrical energy that must be dissipated before it charges the internal capacitors to an overvoltage condition. All the circuits in this section are "hot", that is, they connect directly to the mains and must be considered high-voltages and a shock hazard requiring proper insulation techniques during installation.

GROUNDING

A grounding system has three primary functions: safety, voltage-reference, and shielding. As a safety measure, the primary ground at J1-3 will carry fault-currents from the mains in the case of an internal failure or short-circuit of electronic components. Wiring to this is typically done with the green conductor with yellow stripe using the same gauge wire as that used for the mains. The pin on the drive at J1-3 is longer than the other pins on J1 giving it a first-make, last-break action so that the drive chassis is never ungrounded when the mains power is connected. This wire is a 'bonding' conductor that should connect to an earthed ground point and must not pass through any circuit interrupting devices.

All of the circuits on J1, J2, J3, and J4 are mains-connected and must never be grounded. The frame ground terminals at J1-3, J2-3, J3-1, J4-1, J6-1, J9-1, J10-1, J11-1, and J12-1 all connect to the drive chassis and are isolated from all drive internal circuits.

Signal grounding references the drive control circuits to those of the control system. These controls circuits typically have their own earth connection at some point. To eliminate ground-loops it is recommended that the drive signal ground be connected to the control system circuit ground. When this is done the drive signal voltages will be referenced to the same 0 V level as the circuits in the control system. Small currents flow between controller and drive when inputs and outputs interact. The signal ground is the path for these currents to return to their power sources in both controller and drive.

Shields on cables reduce emissions from the drive for CE compliance and protect internal circuits from interference due to external sources of electrical noise. Because of their smaller wire gauge, these should not be used as part of a safety-ground system. Motor cases can be safety-grounded either at the motor, by earthing the frame, or by grounding conductors in the motor cables that connect to J3-1 & J4-1. These cables should be of the same gauge as the other motor phase cables.

For CE compliance and operator safety, the drive heatplate should be earthed to the equipment frame. An unplated tab is provided on the heatplate (near to J1) for this connection.

REGENERATION

The chart below shows the energy absorption in W·s for an XP2 drive operating at some typical mains voltages. When the load mechanical energy is greater than these values an external regen resistor is available as an accessory. The capacitor bank is 2350 µF and the energy absorption is shared with both axes.

ENERGY ABSORPTION

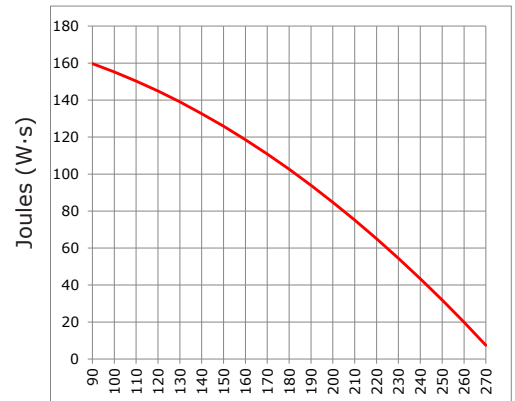

VAC MAINS

POWER, REGEN, & BRAKE CONNECTIONS

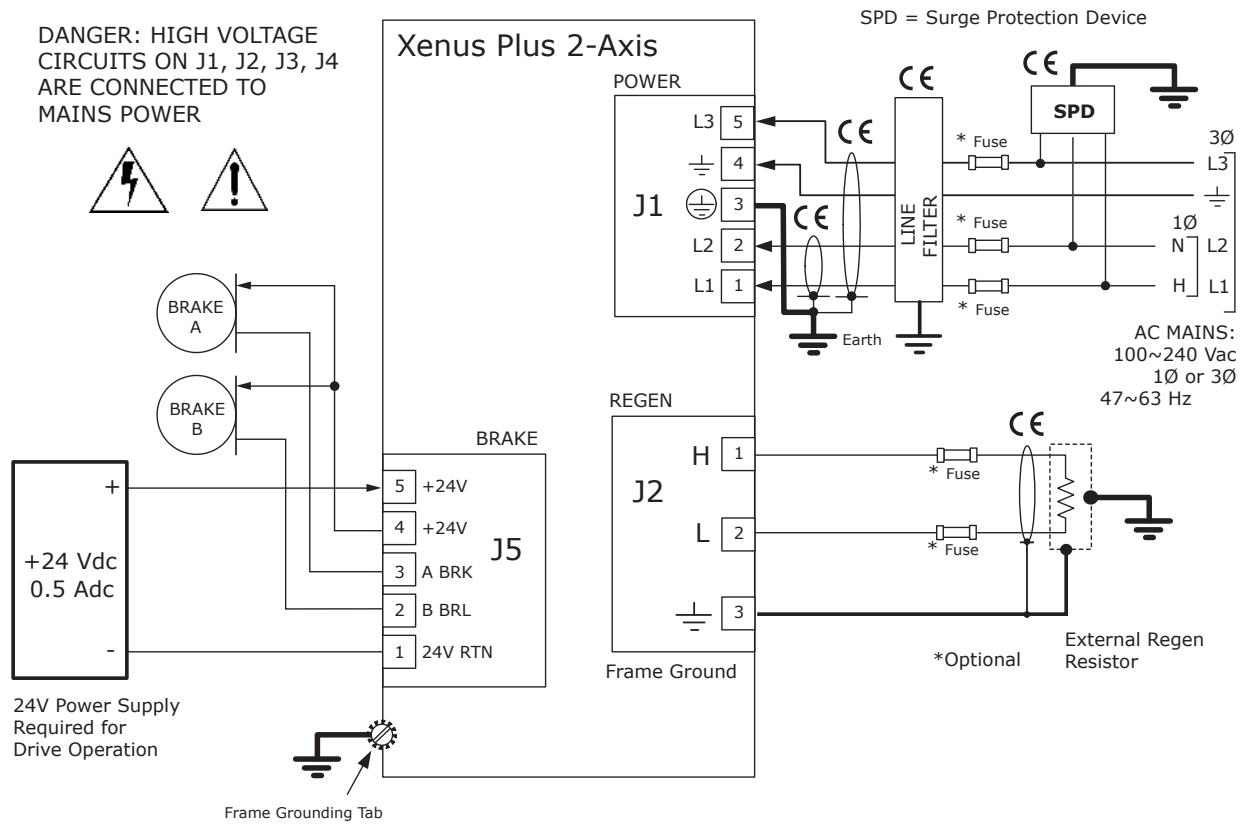

Keep the chassis grounding connections short for best shielding performance

Notes:

- 1) Items marked with CE are required for standards conformance.
- 2) In the end product installation, a UL RC (Recognized Component) SPD (Surge Protective Device) type 1CA, 2CA, 3CA or a UL Listed (VZCA) SPD type 1, 2, or 3 rated 2500 V, with a minimum SCCR of 5 kA, 240 Vac, and surge voltage monitoring needs to be provided if the over-voltage category of the installation is greater than Category II. When this occurs, the purpose of the SPD is to establish an over-voltage CAT II environment for the drives.
- 3) The line filter used in CE conformance testing was a Filter Concepts 3F15.
- 4) Fuses and/or circuit breakers are optional and can be selected by the user to meet local codes and/or machine construction requirements.
- 5) The internal regen resistor of the XP2 must be unplugged when using an external regen resistor. Only one regen resistor can be connected to the Regen connector J2.

GROUNDING & SHIELDING

Grounding for Safety

The protective earth (PE) ground at J1-3 (for both single and dual axis drives), is the electrical safety ground and is intended to carry the fault currents from the mains in the case of an internal failure or short-circuit of electronic components. Wiring to this ground should be done using the same gauge wire as that used for the mains. This wire is a "protective bonding" conductor that should be connected to an earthed ground point and must not pass through any circuit interrupting devices. The PE ground also connects to the drive heatplate (Frame Ground, FG). Connections of the regen and motor cable shields to the FG points (J2-1, J3-1) is done to prevent the motor or regen resistor housing from becoming hazardous in the event of an insulation failure. Protective earth connections for the motor and regen resistor housings are subject to local electrical codes and must be reviewed for compliance with those codes. It is the responsibility of the end user to

ensure compliance with local electrical codes and any other applicable standards. It is strongly recommended that motor and regen resistor housings also be connected to protective earth connection points located as close to the motor and regen resistor as possible. In many applications, the machine frame is used as a primary or supplemental protective earth connection point for the motor and regen resistor housings

Grounding and Shielding for CE Compliance

These connections are the means of controlling the emission of radio frequency energy from the drive so that it does not interfere with other electronic equipment. The use of shielded cables to connect the drive to motors and feedback devices is a way of extending the chassis of the drive out to these devices so that the conductors carrying noise generated by the drive are completely enclosed by a conductive shield. The FG ground terminals provide cable

shield connection points for the motor, feedback, and regen resistor cables. By connecting the shields for these devices at the drive and at the device, the connection is continuous and provides a return path for radio-frequency energy to the drive.

To further minimize electrical noise it is important to keep the connection between the drive heatplate and earth/equipment frame as short as possible. A Heatplate Grounding Screw is provided for making this connection.

Grounding for Leakage Current Requirements

The connection to the Heatplate Grounding Screw also provides a second protective earthing conductor to address the touch current requirements of IEC 61800-5-1. Further information on this topic can be found in the Xenus Plus User Guide.

HEATPLATE GROUNDING SCREW

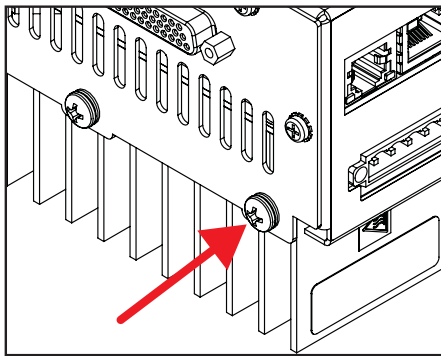

Keep the chassis grounding connections short for best shielding performance

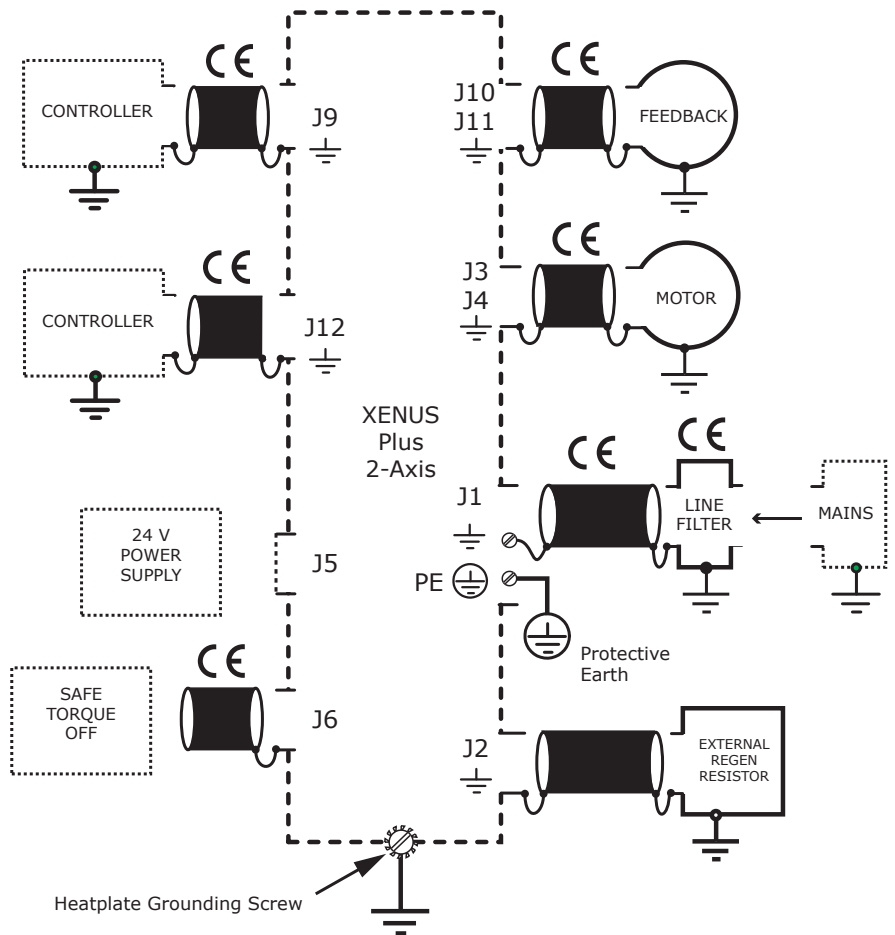

Notes:

- 1) Shielded cables required for CE are shown in the diagram above.
- 2) Line filter required for CE

REGENERATION

The drive has an internal regen resistor which can handle regenerative energy that exceeds the absorption capacity of the internal bus capacitance. The internal regen resistor will be switched on when the energy shown in the table has been absorbed and the bus voltage driven up to 390 Vdc at which point the internal regen resistor will be switched to absorb the kinetic energy of the load.

ABSORPTION

Vac	E
100	155
120	145
200	85
240	43

Absorption is the energy that can be transferred to the internal capacitors during deceleration. This table shows the energy absorption in W-s for a drive operating at some typical mains voltages. The capacitor bank is 2350 uF and the energy absorption is shared with both axes. If the deceleration energy is less than the absorption capacity of the drive, then a regeneration resistor will not be used because the bus voltage will not rise enough to hit the over-voltage level that would disable the PWM outputs.

Terms:

E	Energy	Joules, Watt-seconds
J	Rotary Moment of Inertia	kg·m ²
P	Power	Watts

CALCULATING THE REGEN REPETITION FREQUENCY

Step 1: Find the energy of motion for a rotating load, for this example let it be 75 Joules:

$$E = J * RPM^2 = 75 J \quad \text{Joules; kg·m}^2, \text{ RPM}$$

$$\underline{\quad 182 \quad}$$

Step 2: Subtract the absorption at your mains voltage to get the energy that must be dissipated in the regen resistor. Use 240 Vac:

$$75J - 43J = 32 J \quad \text{Joules; Joules}$$

Step 3: Divide the regen energy by the continuous power rating of 20 Watts to get the dwell time that can dissipate the regen energy in the resistor:

$$\text{Dwell Time} = \frac{32 \text{ Joules}}{20 \text{ Watts}} = 1.6 \text{ sec}$$

Seconds; Joules, Watts

Step 4: Find the total regen cycle time by adding the deceleration time to the dwell time:

Decel Time = 1.25 sec
 Dwell Time = 1.60 sec
 Cycle Time = 2.85 sec

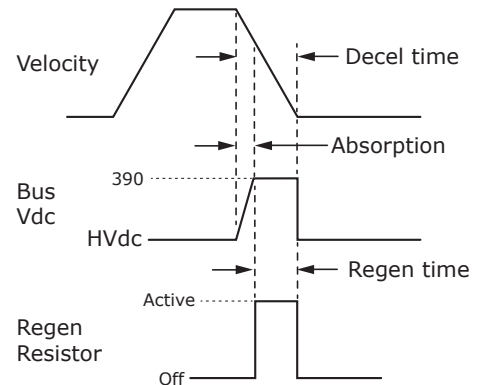

INTERNAL REGEN RESISTOR

Max Energy	100 W·s (J)
Resistance	18 W
Power, continuous	20 W
Power, peak	70 W
Time	2000 ms

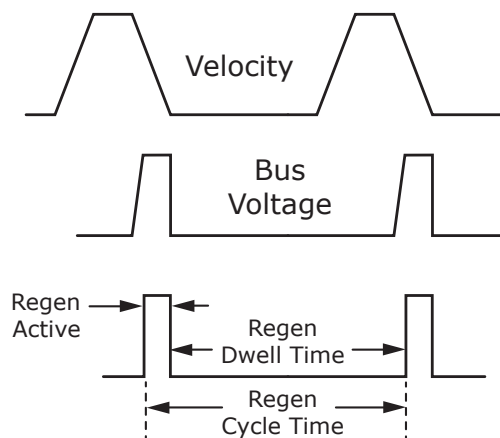

DIMENSIONS

Units: in [mm]

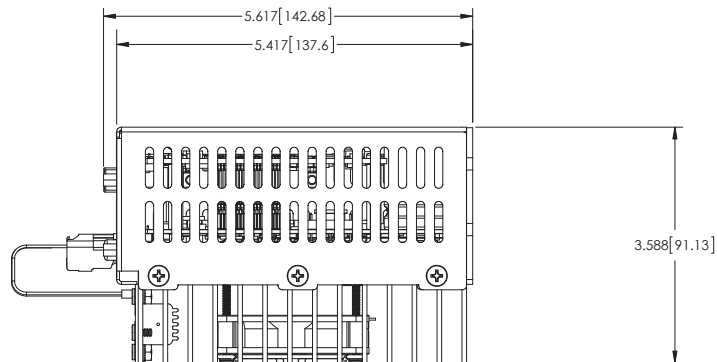
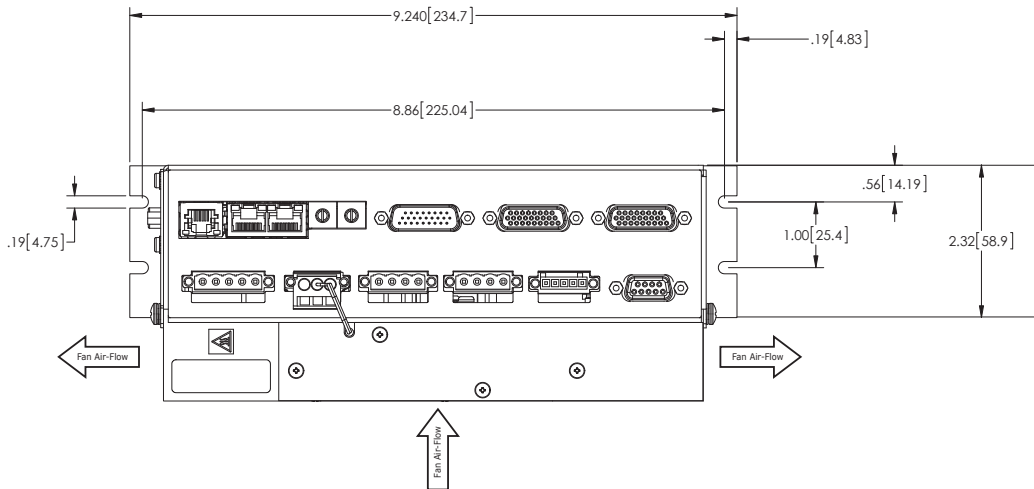
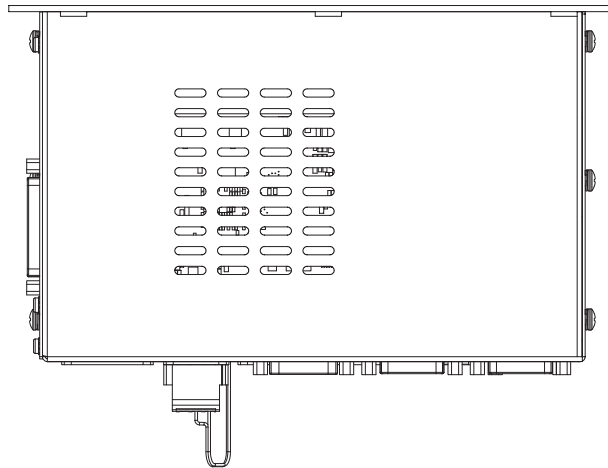

Weight:
4.19 lb [1.90kg]

ORDERING INFORMATION

XP2-230-20	XP2 Servo Drive 10/20 Adc, Encoder feedback
XP2-230-20-R	XP2 Servo Drive 10/20 Adc, Resolver feedback



Example: Order one Xenus Plus XP2 drive, resolver version, solder-cup connector Kit, CME 2 CD, serial cable kit

Qty	Item	Remarks
1	XP2-230-20-R-H	Xenus Plus XP2 servo drive with resolver
1	XP2-CK-02	Connector Kit
1	CME 2	CME 2 CD
1	SER-CK	Serial Cable Kit

ACCESSORIES

	Qty	Ref	Name	Description	Manufacturer P/N
XP2-CK Connector Kit	1	J1	AC Pwr	Plug, 5 position, 5.08 mm, female	Wago: 231-305/107-000 (Note 1)
	1			Strain relief, snap-on, 5.08 mm, 5 position, orange	Wago: 232-635
	1	J2	Regen	Plug, 3 position, 5.08 mm, female	Wago: 231-303/107-000 (Note 1)
	1			Strain relief, snap-on, 5.08 mm, 3 position, orange	Wago: 232-633
	2	J3,J4	Motor	Plug, 4 position, 5.08 mm, female	Wago: 231-304/107-000 (Note 1)
	2			Strain relief, snap-on, 5.08 mm, 4 position, orange	Wago: 232-634
	1	J5	Brake	Plug, 5 position, 3.5 mm, female	Wago: 734-105/107-000 (Note 1)
	1			Strain relief, snap-on, 3.5 mm, 5 position, grey	Wago: 734-605
	1	J5	Tool	Tool, wire insertion & extraction, 734 series	Wago: 734-231
	4	J1, J2, J3, J4	Tool	Tool, wire insertion & extraction, 231 series	Wago: 231-159
	1	J6 Note 2	Safety	Connector, DB-9M, 9-position, standard, male	TE/AMP: 205204-4
	9			AMPLIMITE HD-20 Crimp-Snap contacts, 24-20AWG, AU flash	TE/AMP: 66506-4
	1			Metal Backshell, DB-9, RoHS	3M: 3357-9209
	4			Jumper, with pins crimped on both ends	Copley: 10-75177-01
	1	J12	Control	Connector, high-density DB-44M, 44 position, male, solder cup	Norcomp: 180-044-103L001
	1			Metal Backshell, DB-25, RoHS	3M: 3357-9225
	1	J9	I/O	Connector, high-density DB-26F, 26 position, female, solder cup	Norcomp: 180-026-203L001
	2	J10~11	Feed-back	Connector, high-density DB-26M, 26 position, male, solder cup	Norcomp: 180-026-103L001
3	J9~11	Metal Backshell, DB-15, RoHS		3M: 3357-9215	
SER-CK	1	J7	RS-232	Serial Cable Kit	
XP2-NC-10	1	J8	Network	CAN network cable, 10 ft (3 m)	
XP2-NC-01	1			CAN network cable, 1 ft (0.3 m)	

Note 1: For RoHS compliance, append "/RN01-0000" to the Wago part numbers listed above

Note 2: Insertion/extraction tool for J6 contacts is AMP/Tyco 91067-2 (not included in XP2-CK)

REGENERATION RESISTOR (OPTIONAL)

XTL-RA-04	1	J2	Regeneration resistor assembly, 15 Ω
-----------	---	----	--------------------------------------

EDGE FILTER (OPTIONAL, ONE REQUIRED FOR EACH AXIS. QUANTITIES BELOW ARE FOR ONE FILTER AND ONE CONNECTOR KIT)

XTL-FA-01	1	J3~4	Edge filter	
Edge Filter Connector Kit XTL-FK	1		Plug, 4 position, 5.0 mm, female	Wago: 721-104/026-047 (Note 1)
	1		Plug, 5 position, 5.0 mm, male	Wago: 721-605/000-044 (Note 1)
	2		Tool, wire insertion & extraction	Wago: 231-131

16-01418 Document Revision History

Revision	Date	Remarks
00	May 17, 2016	Initial released version
02	March 22, 2017	Update for Agile, ECO-066066, one absolute encoder per axis restriction added

Note: Specifications are subject to change without notice